

Series 952



INSTALLATION MANUAL

LINEAR DISPLACEMENT TRANSDUCERS

952 Blue0x

Linear Displacement Transducer



**ABSOLUTE PROCESS CONTROL
KNOW WHERE YOU ARE... REGARDLESS**





Contents

Chapter 1: Overview.....2
 1.1 Dimension Drawing for all 952 LDTs3

Chapter 2: Installing the LDT.....4
 2.1 Installing the LDT to a Mounting Bracket.....4
 2.2 Installing the LDT in a Hydraulic Cylinder.....5

Chapter 3: 952 Wiring (A, CP, RS, VP, VPI).....8
 3.1 952 Analog - V0, V1, V4 or V5 (Voltage).....9
 3.2 952 Analog - C4 or C2 (Current).....9
 3.3 952 Analog - D0 or D1 (Differential Analog Output).....9
 3.4 952 Analog Wiring10
 3.5 952A (Analog)11
 3.6 952 CP (Control Pulse).....11
 3.7 952 VP (Variable Pulse)12
 3.8 952 RS (Start/Stop)13
 3.9 952 CP, RS, VP Wiring14
 3.10 Setting Zero & Span Position (Analog Only)15
 3.11 Differential Analog Output (Options D0, D1, or D2)15

Chapter 4: 952 QD Overview16
 4.1 Quadrature Output.....16
 4.2 Signal Connection Application Note16
 4.3 Quadrature Output Resolution and Speed18
 4.4 952 QD Wiring Connection.....18
 4.5 Features19
 4.6 952 QD Wiring Diagram20
 4.7 952 QD Frequency23

Appendix A: Troubleshooting.....24
 A.1 Troubleshooting for 952 Analog LDTs24
 A.2 Troubleshooting for 952 Analog LDTs26
 A.3 Troubleshooting for 952 CP, RS, or VP LDTs27

Appendix B: Ordering Information29
 B.1 Analog Part Numbering29
 B.2 Digital Part Numbering30
 B.3 Quadrature Part Numbering.....31

Appendix C: Specifications.....32

Glossary34

NOTE: AMETEK has checked the accuracy of this manual at the time it was approved for printing. However, this manual may not provide all possible ways of installing and maintaining the LDT. Any errors found in this manual or additional possibilities to the installation and maintenance of the LDT will be added in subsequent editions. Any comments you may have for the improvement of this manual are welcomed.

AMETEK reserves the right to revise and redistribute the entire contents or selected pages of this manual. All rights to the contents of this manual are reserved by AMETEK. BlueOx is a registered trademark of GEMCO.

Chapter 1: Overview

The GEMCO Model 952 BlueOx is a Magnetostrictive Linear Displacement Transducer (LDT). Each LDT offers highly accurate position sensing. The BlueOx LDT is built to withstand the most severe environmental conditions. The 952 digital and analog LDTs are completely absolute. Power loss will not cause the unit to lose position information or require re-zeroing. Also, the non-contact design allows this device to be used in highly repetitive applications without mechanical wear.

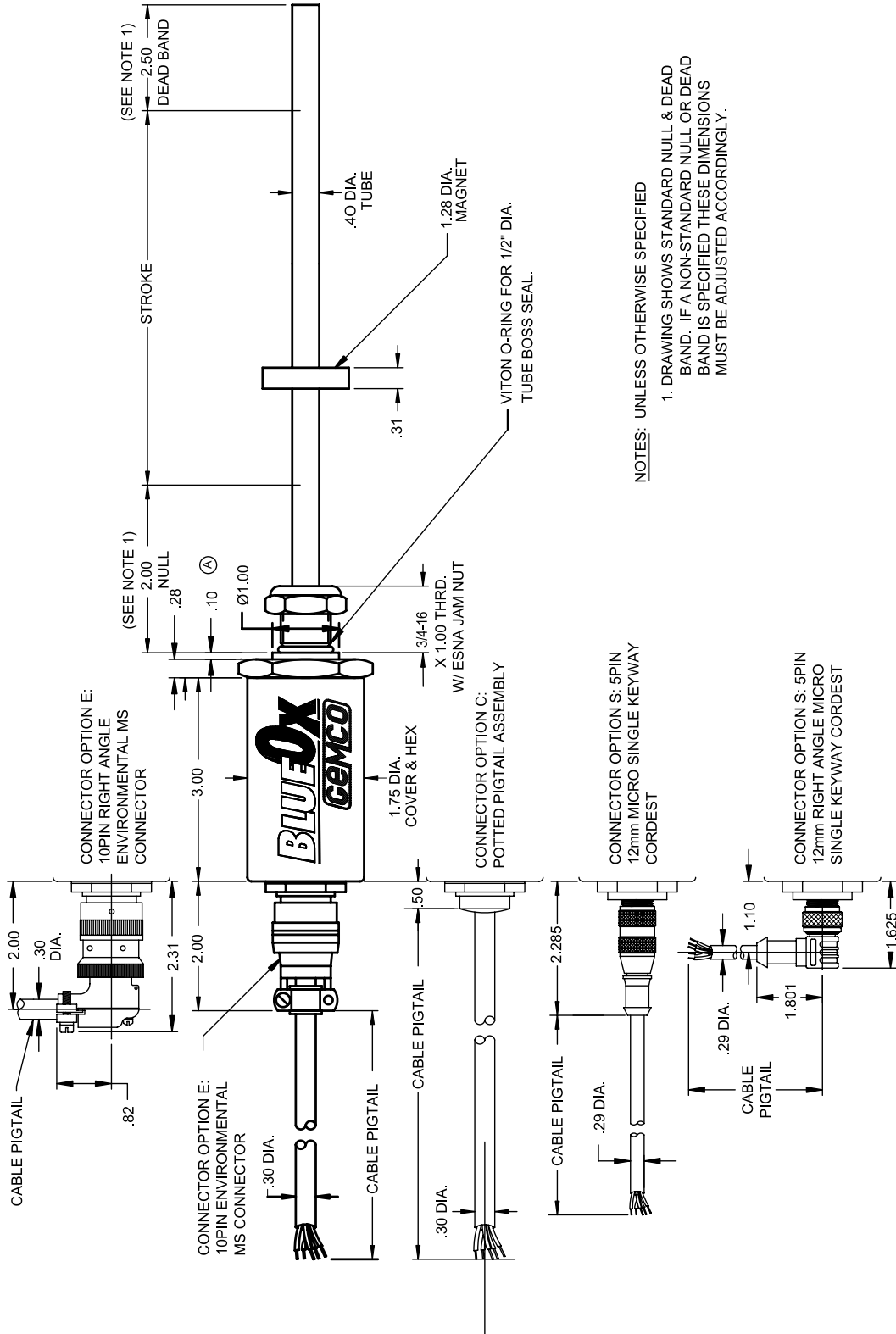
NOTE: The series number on the LDT is a record of all the specific characteristics that make up the unit. This includes what interface type it is; its wire speed (for digital LDTs); its output signal and range; the type of connector the unit uses; and stroke, null and dead band lengths. For a translation of the model number, see Appendix B: Ordering Information.

The GEMCO 952 QD BlueOx is a magnetostrictive Linear Displacement Transducer (LDT) for continuous machine positioning in a variety of industrial applications. The quadrature output makes it possible to have a direct interface to virtually any incremental encoder input or counter card, eliminating costly absolute encoder converters and special PLC interface modules.

The 952 QD BlueOx quadrature LDT can be ordered with 1 to 9999 cycles per inch of output resolution. The transducer features an input to re-zero the probe on the fly. Another unique feature is the Burst mode; an input on the transducer triggers a data transfer of all the incremental position data relative to the transducer’s absolute zero position. This is how incremental can provide absolute functionality. The Burst input can be used to achieve absolute position updates when power is restored to the system or anytime an update is needed to re-zero or home the machine.



1.1: Dimension Drawing for all 952 LDTs



NOTES: UNLESS OTHERWISE SPECIFIED
 1. DRAWING SHOWS STANDARD NULL & DEAD BAND. IF A NON-STANDARD NULL OR DEAD BAND IS SPECIFIED THESE DIMENSIONS MUST BE ADJUSTED ACCORDINGLY.

Figure 1-1: BlueOx Linear Displacement Transducer Drawing D0234200



Chapter 2: Installing the LDT

Before installing the LDT, the following should be considered:

- If a mounting bracket is used that is made of ferromagnetic material (a material readily magnetized), it should be placed no closer than 0.25" from the LDT's rod end.
- To minimize the effects of magnetic flux distortion (which could cause an inaccurate measurement of the magnet's position), ferromagnetic material should not be placed closer than 0.25" from the magnet.

2.1: Installing the LDT to a Mounting Bracket

Perform the following steps to install the LDT to a mounting bracket. Parts discussed in this section are found in Figure 1-1. If the LDT is being installed into a hydraulic cylinder, refer to Section 2.2:

Installing the LDT in a Hydraulic Cylinder.

1. Unscrew the LDT's jam nut from the threads protruding from the hex mounting base.
2. Insert the LDT's rod end into the mounting bracket's hole. The mounting bracket may contain a 3/4 – 16 UNF – 2B threaded hole. In this case, screw the LDT into this hole using the threads protruding from the hex mounting base.
3. Once the LDT is in place, screw the jam nut back onto the threads of the hex mounting base. Use the 1.75" hex mounting base on the head assembly to tighten the LDT to the bracket.

WARNING: Do not use the blue aluminum cover of the head assembly or connector/cable nut (either a 1 1/16" Amphenol connector or 1 3/16" cable nut) to tighten the LDT within the bracket (see Figure 2-1). This may damage the LDT and will void your warranty. To tighten the LDT within the bracket, use the 1.75" hex mounting base on the head assembly.

If the length of the LDT's rod end is less than 30", skip to the sub-section: Mounting the Magnet Assembly.

Installing Support Brackets

It is recommended that a support bracket be used with LDTs having a rod 30"-71" in length. Supporting the end of the rod will minimize operational errors and protect against damage due to shock and vibration. If the length of the LDT's rod is 72" or longer, it is recommended that additional support brackets be used. These additional support brackets must be made of a non-ferrous material. Because these additional support brackets will interfere with the magnet's movement, a special split-type magnet assembly must be used. To order a split magnet (part number SD0411200) and support brackets (part number SD0411100), contact Factory.

To install a support bracket for a LDT having a rod 30"-71" in length, perform step 4a. If the rod is longer than 71", perform step 4b.

- 4a. If the support bracket is made of a ferromagnetic material (material readily magnetized), install the support bracket no closer than 0.25" from where the LDT's dead band ends and the area of stroke begins. Continue to the sub-section: Mounting the Magnet Assembly.

To install two or more support brackets for a LDT having a rod 72" or longer in length, perform the following steps:

- 4b. Install support brackets at increments of 48" throughout the LDT's rod. Support brackets placed within the null zone and area of stroke or closer than 0.25" to the beginning of these areas must be made of a non-ferrous material.



Mounting the Magnet Assembly

Before mounting the magnet assembly, the following should be considered:

- Ferromagnetic material should not be placed closer than 0.25" from the LDT's magnet assembly or rod end. Failure to do so could cause erratic operations. Non-ferrous materials, such as brass, copper, aluminum, non-magnetic stainless steel, or plastics, can be in direct contact with the magnet assembly and rod end without producing any adverse results.
- Minimal clearance between the LDT's rod and the magnet assembly through the full stroke is required. Stress between the magnet and the rod can cause flexing of the mounting brackets. This may appear as nonlinearity.
- LDTs using a split magnet assembly must keep the diameter of the magnet assembly around the rod throughout the complete stroke. The diameter of this magnet assembly should not be farther than 0.2" away from the rod. Split magnet assemblies outside this range will cause signal loss.

To install the magnet assembly, perform the following steps:

1. Slide the magnet assembly over the LDT rod.
2. Mount the magnet to the non-ferrous, movable portion of the device being controlled using non-ferrous screws.

2.2: Installing the LDT in a Hydraulic Cylinder

Before installing an LDT in a hydraulic cylinder, note the following considerations. Items discussed in this section are found in Figures 1-1 and 2-1.

- A non-ferrous spacer must be used to separate the magnet assembly from the head of the piston rod. See Figure 2-1.

- The magnet should not be closer than 2.0" from the base of the LDT's hex head when the piston rod is fully retracted. In instances where space restraints exist, it may be required to countersink the magnet into the piston rod. Two magnets are available for mounting to the piston: the standard 1.29" in diameter (part number SD0400800) four-hole magnet and a 1.0" magnet (part number SD0410300) designed exclusively for countersunk mounting applications. The 1.0" magnet must be held captive with a snap ring.
- An O-ring groove is provided at the base of the LDT's mounting hex for pressure sealing. The O-Ring seal was designed to meet Mil-Std-MS33656. Refer to SAE J514 or SAE J1926/1 for machining of mating surfaces.
- It is recommended that a chamfered rod bushing be used with LDTs having a rod 60.0" or longer in length. On applications with rods of this length, a chamfered rod bushing in front of the magnet may be required. This bushing will prevent wear on the magnet assembly (wear occurs as the piston retracts from extended lengths). This rod bushing should be manufactured from a high wear polymer, such as Teflon®.
- It is recommended the bore for the cylinder piston rod have an inside diameter of at least 0.50". The LDT rod has an outside diameter of 0.405". Use standard practices for machining and mounting these components. Consult the cylinder manufacturer for details on applicable SAE or military specifications.

Before performing the following steps for installing the LDT into a hydraulic cylinder, it may be necessary to perform machining and mounting operations on the hydraulic cylinder. Consult the information and specifications provided by the cylinder manufacturer before beginning the following steps:

1. Unscrew the LDT's jam nut from the threads protruding from the hex mounting base.

- Position the non-ferrous spacer against the piston face, followed by the magnet, and finally the chamfered rod bushing. (If the length of the LDT's rod is 60.0" or longer in length, it is recommended that a chamfered rod bushing be used.)
- Insert non-ferrous screws through the chamfered rod bushing (if used), magnet, and non-ferrous spacer, and secure items by tightening screws.

If the leading edge of the magnet will come closer than 2.0" from the base of the LDT's hex head when the piston rod is fully retracted, it will be necessary to counterbore the magnet assembly into the piston rod. Both the standard 1.29" four-hole magnet assembly (part number SD0400800) and the 1.0" magnet assembly (part number SD0410300) are designed for counterbored mounting applications. If it has a 1.0" magnet assembly, a snap ring will be needed to hold it in place.

- Insert the LDT's rod into the hole of the hydraulic cylinder's mounting bracket.

The protective Plug may need to be removed from the hydraulic cylinder before inserting the LDT. The end cap should contain a 3/4 - 16 UNF - 2B threaded hole. Screw the LDT into this hole using the threads protruding from the LDT's hex mounting base.

WARNING: Do not use the blue aluminum cover of the head assembly or connector/cable nut (either a 1 1/16" Amphenol connector or 1 3/16" cable nut) to tighten the LDT within the bracket (see Figure 2-1). This may damage the LDT and will void your warranty. To tighten the LDT within the bracket, use the 1.75" hex mounting base on the head assembly.

At this point, the LDT should now be properly installed inside the hydraulic cylinder. It may now be necessary to assemble parts of the hydraulic cylinder. For assistance in this task, refer to the information provided by the cylinder manufacturer.

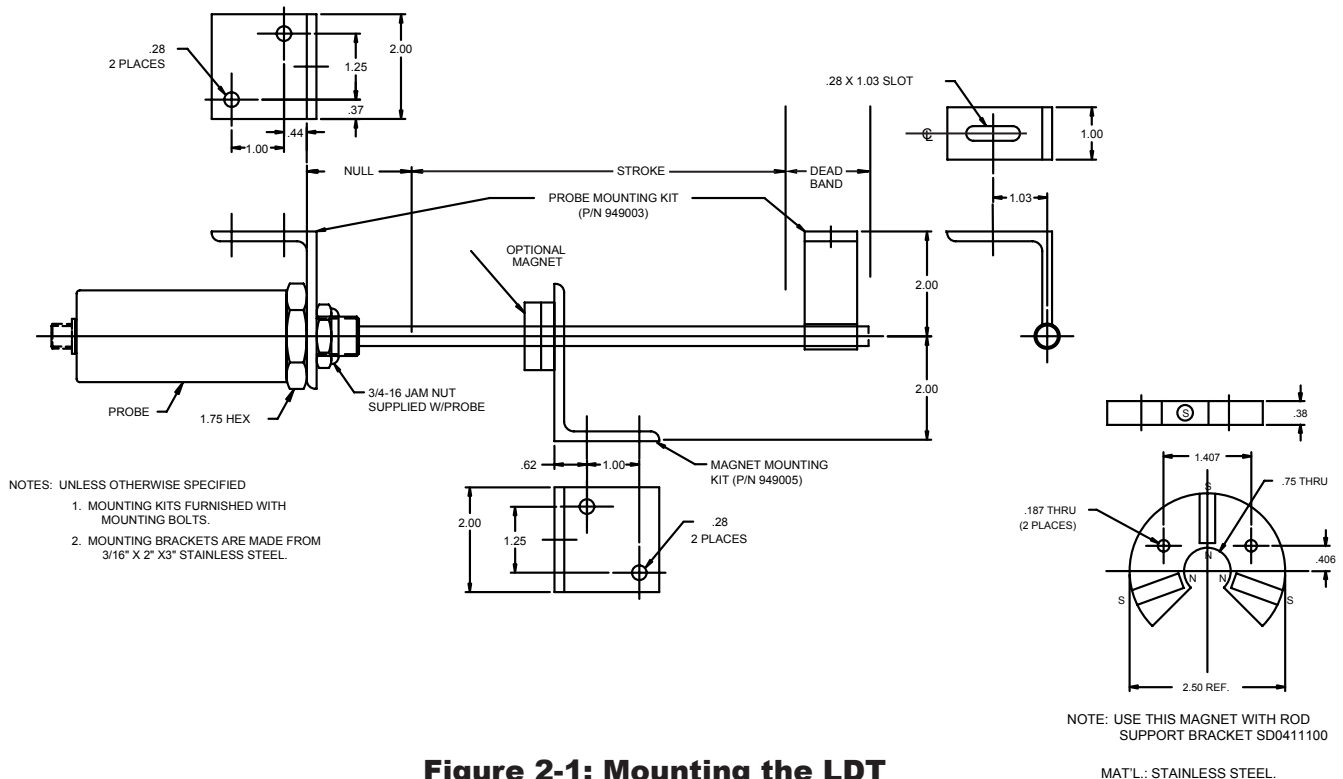


Figure 2-1: Mounting the LDT

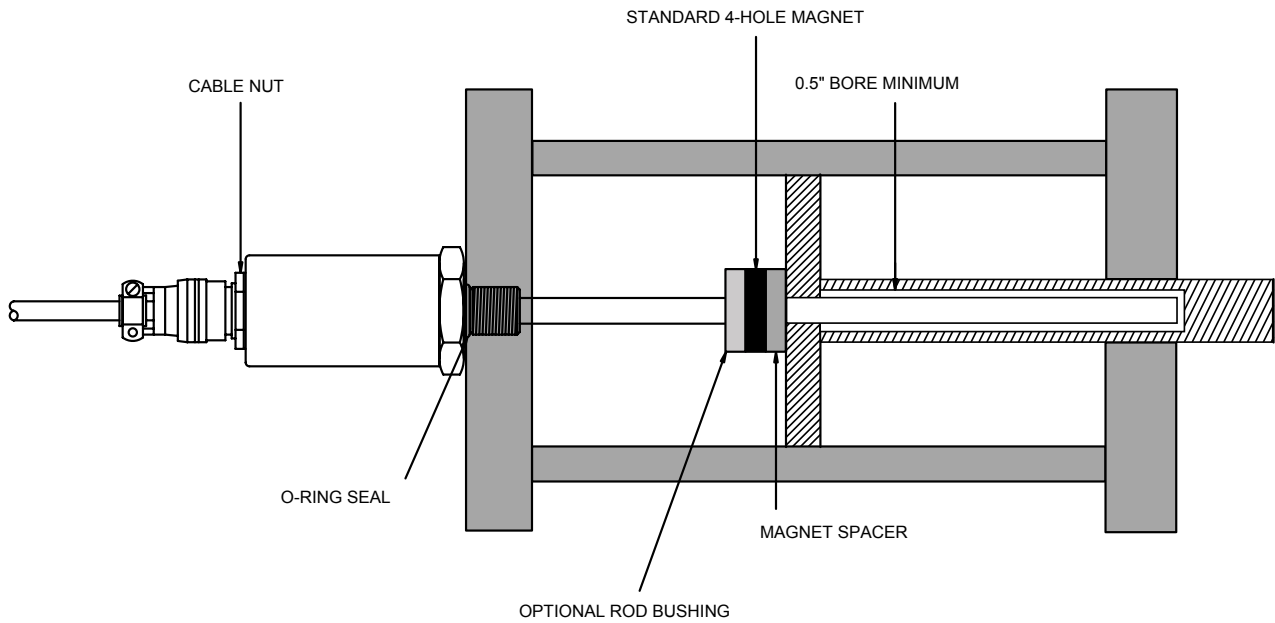


Figure 2-2: Mounting LDT in a Hydraulic Cylinder

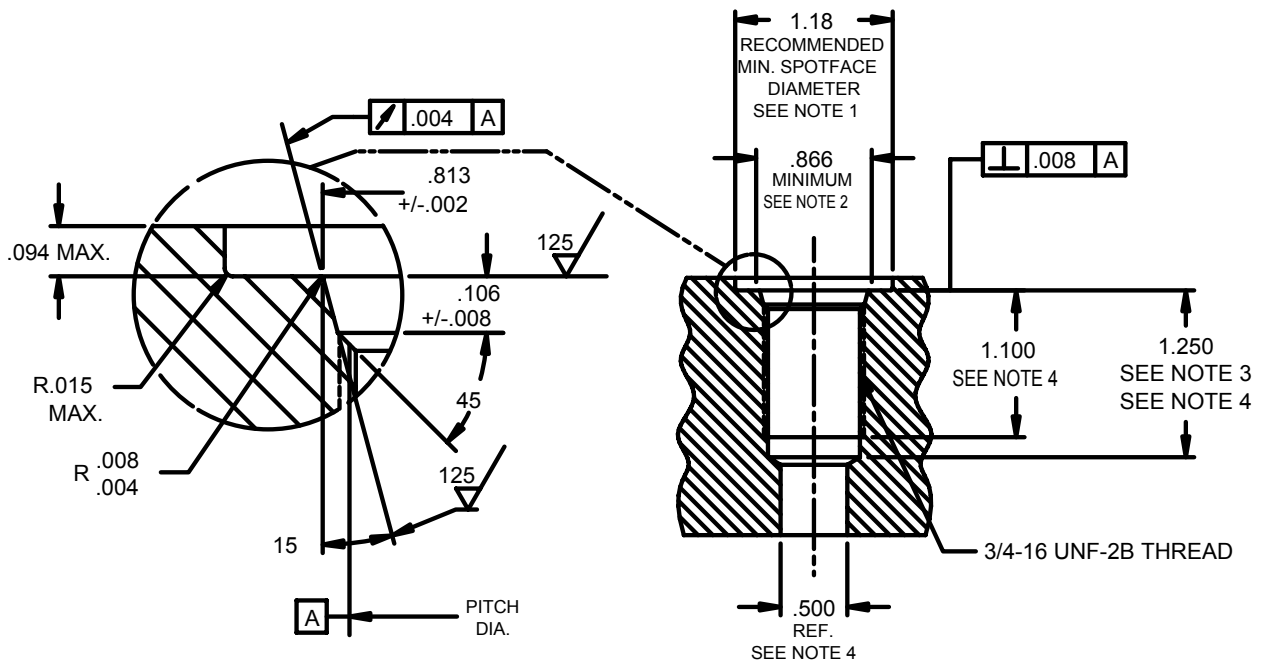


Figure 2-3: Port Detail (SAE J1926/1)

Chapter 3: 952 Wiring Connections

Once the LDT has been installed, wiring connections can be made. There are two groups of connections that will need to be made. They are as follows:

- Power Supply Connections (including grounding and shielding)
- LDT Input/Output Connections

Power Supply/Ground Connections

The BlueOx standard cable is Alpha XTRA-GUARD 2 25110 SUPRASHIELD™, a multi-conductor cable with a specially formulated polyurethane jacketing, 10 conductors of 22 ga, with an aluminum/polyester/aluminum foil with drain wire plus an overall braid of tinned copper shield. Cable O.D. is .30. Connector option S, used only on the analog version, use an industry standard 5 pin 12mm Euro style cordset with a shield tied to the coupling nut. To reduce electrical noise the shield must be properly used. Connect the cable's shield to the controller system GND. The cable shield is not connected at the transducer rod. Always observe proper grounding techniques such as single point grounding and isolating high voltage (i.e. 120/240 VAC) from low voltage (15 - 26 VDC cables for digital LDTs) and (13.5 - 30 VDC cables for analog LDTs).

WARNING: Do not use molded cordsets with LED's!

It is preferable that the cable between the LDT and the interface device be one continuous run. If you are using a junction box, it is highly recommended

that the splice junction box be free of AC and/or DC transient-producing lines. The shield should be carried through the splice and terminated at the interface device end.

NOTE: When grounding the LDT, a single earth ground should be connected to the power supply common (circuit ground). The LDT power supply common (pin B) should be connected to the power supply common (-) terminal. Pin C should be connected to the power supply positive terminal (+). The LDT cable shield should be tied to earth ground at the power supply. The LDT analog common should not be connected to earth ground and should be used for connection to interface devices only. For assistance, refer to your LDT's wiring drawing in this chapter.

Bipolar Wiring

If using the bipolar option, ensure that the power supply is rated at ± 15 VDC at 100mA for each polarity. The power supply should provide less than 1% ripple with 10% regulation. **The power supply should be dedicated to the LDT to prevent noise and external loads from affecting the BlueOx performance.** See Figure 3-1. For more wiring information, see wiring diagram in this chapter. Be sure to identify the proper version of the LDT. A linear supply should always be used with any LDT.

NOTE: Do not use Bipolar Wiring for 952A or 952 QD. See Section 3.4 for 952A wiring details and Section 4.6: 952 QD Wiring Connections, for wiring details.

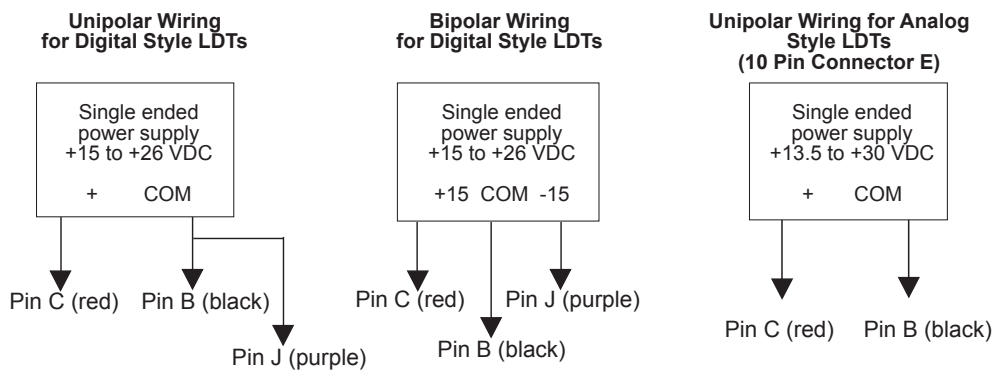


Figure 3-1: Power Supply Wiring (Unipolar/Bipolar)

WARNING: Do not route the BlueOx cable near high voltage sources.



WARNING: Do not use the blue aluminum cover of the head assembly or connector/cable nut (either a 1 1/16" Amphenol connector or 1 3/16" cable nut) to tighten the LDT within the bracket (see Figure 2-1). This may damage the LDT and will void your warranty. To tighten the LDT within the bracket, use the 1.75" hex mounting base on the head assembly.

At this point, the LDT should now be properly installed inside the hydraulic cylinder. It may now be necessary to assemble parts of the hydraulic cylinder. For assistance in this task, refer to the information provided by the cylinder manufacturer.

Unipolar Wiring

In order for the BlueOx to operate properly, the LDT's external power supply must provide a voltage between +13.5 to +30 VDC for analog and +15 to +26 VDC for digital style LDTs. The power supply must be rated at 250mA minimum. The power supply should provide less than 1% ripple with 10% regulation.

The power supply should be dedicated to the LDT to prevent noise and external loads from affecting the BlueOx. When powering up more than one BlueOx on a single power supply, each BlueOx will draw no more than 250mA.

3.1: 952 Analog - V0/V1 (Voltage)

The 952A-V LDT generates a voltage output based on position. The 952A BlueOx with analog output offers 16 bits of resolution and is fully programmable over the entire active stroke length of the LDT. Keep in mind that there is a 2" Null area at the connector end of the LDT and a 2.5" Dead area at the other end of the LDT that the magnet must stay out of at all times. The units come fully programmed from the factory and do not require re-programming unless desired. The analog units are 100% absolute and will not lose programmed parameters on power loss.

The analog output is referenced to the analog common terminal and should not be referenced to any of the other common terminals. To wire the 952A voltage LDT, see Section 3.4 and Figure 3-2. For programming Zero and Span, refer to Section 3.9.

3.2: 952 Analog - C4/C2 (Current)

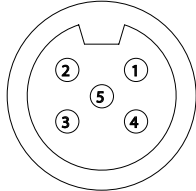
The 952A-C LDT generates a current output based on position. The 952A BlueOx with analog output offers 16 bits of resolution and is fully programmable over the entire active stroke length of the LDT. Keep in mind that there is a 2" Null area at the connector end of the LDT and a 2.5" Dead area at the other end of the LDT that the magnet must stay out of at all times. The units come fully programmed from the factory and do not require re-programming on power loss. The analog output is referenced to the analog common terminal and should not be referenced to any of the other common terminals. To wire the 952A current LDT, see Section 3.4 and Figure 3-2. For programming Zero and Span, refer to Section 3.9.

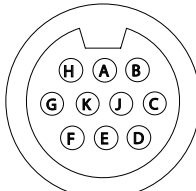
NOTE: 952A-C is current sourcing, which allows the current to flow from the LDT into the user's equipment.

3.3: 952 Analog - D0/D1 (Differential Analog Output)

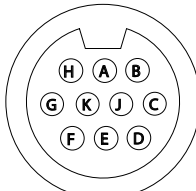
The 952A analog LDT's are available with an optional differential analog output. This feature is hardware specific and must be specified at time of order. The differential feature allows the distance between two magnets to be measured. The magnets must remain within the active stroke range at all times and cannot be any closer than 2.5" to each other. Keep in mind that there is a 2" Null area at the connector end of the LDT and a 2.5" Dead area at the other end of the LDT that the magnets must stay out of at all times. The units come fully programmed from the factory and do not require re-programming unless desired. The analog units are 100% absolute and will not lose programmed parameters on power loss. For programming Zero and Span, refer to Section 3.9.

3.4: 952 - Analog Wiring

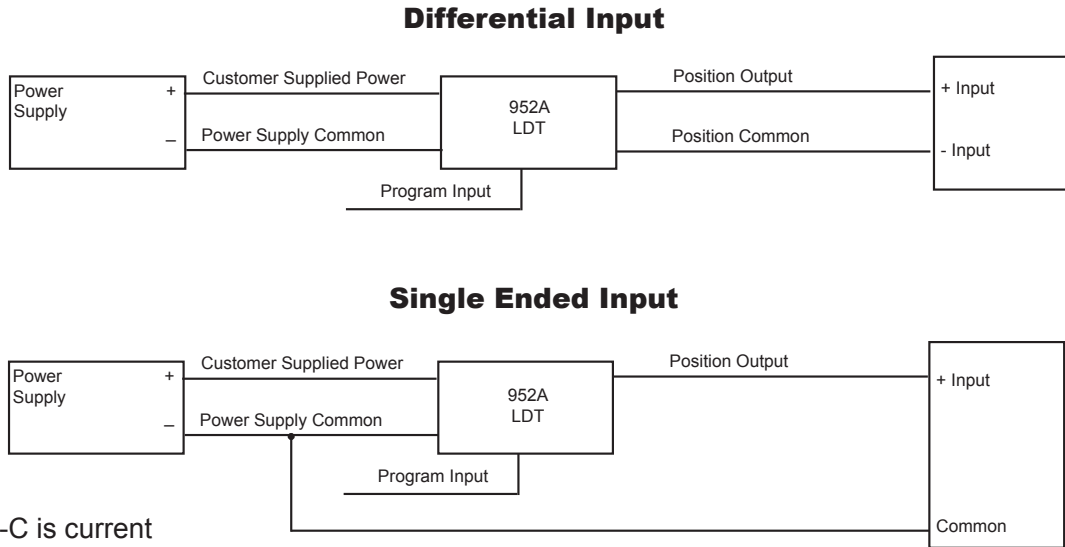
Connector Option S & C	Pin #	Wire Color	Function
 <p>LDT Connector View</p>	1	Brown	Customer Supplied Power (+VDC)
	2	White	Program Input
	3	Blue	Power Supply Common
	4	Black	Position Output
	5	Gray	Position Common

Connector Option E	Pin #	Wire Color	Function
 <p>LDT Connector View</p>	A	White	Frame (No Connection)
	B	Black	Power Supply Common
	C	Red	Customer Supplied Power (+VDC)
	D	Green	No Connection
	E	Brown	Position Output
	F	Blue	Program Input
	G	Orange	No Connection
	H	Yellow	2nd Position Common
	J	Purple	2nd Power Supply Common
	K	Gray	Position Common
	Insulate and tie back any unused wires		

Connector Option T & Q	Pin #	Wire Color	Wire Color Striped	Function
 <p>LDT Connector View MTS® Connector Option RB & RC</p>	1	White	White/Blue Stripe	Power Supply Common
	2	Brown	Blue/White Stripe	No Connection
	3	Gray	White/Orange Stripe	Position Common
	4	Pink	Orange/White Stripe	Position Output
	5	Red	White/Green Stripe	Customer Supplied Power (+VDC)
	6	Blue	Green/White Stripe	No Connection
	7	Black	White/Brown Stripe	No Connection (Position output on pins 3 & 4)
	8	Purple	Brown/White Stripe	No Connection (Position output on pins 3 & 4)
	9	Yellow	White/Gray Stripe	No Connection
	10	Green	Gray/White Stripe	Program Input
GEMCO Style 952A LDTs are programmable for zero and span. Position output is on pin 4				

Connector Option M	Pin #	Wire Color	Function
 <p>LDT Connector View MTS® Connector Option RB & RC</p>	A	White	Power Supply Common
	B		
	C	Gray	Position Common
	D	Pink	Position Output
	E	Red	Customer Supplied Power (+VDC)
	F		
	G	Yellow	No Connection (Position output on pins 3 & 4)
	H	Green	No Connection (Position output on pins 3 & 4)
	J		
	K		
	GEMCO style 952A LDTs are programmable for zero and span. Position output is on Pin D		

3.5: 952A (Analog)



NOTE: 952A-C is current sourcing, which allows the current to flow from the LDT into the user's equipment.

Figure 3-2: Current Sourcing

3.6: 952 CP (Control Pulse)

The control pulse signal interface of the BlueOx digital output series is a differential RS-422 output. The maximum cable length for the differential digital LDTs is 1,500 feet. To initiate a start pulse, an external device is used. This start pulse should be 1.0 microsecond in duration. After the start pulse

is received, the LDT will generate a stop pulse of 1.0 microsecond in duration. The time between the leading edge of the start pulse to the leading edge of the stop pulse is the proportional distance between the magnet to the hex head. The order of these two pulses is illustrated in Figure 3-3. To wire the 952CP, see Figure 3-7. For proper grounding information, see the beginning of this chapter.

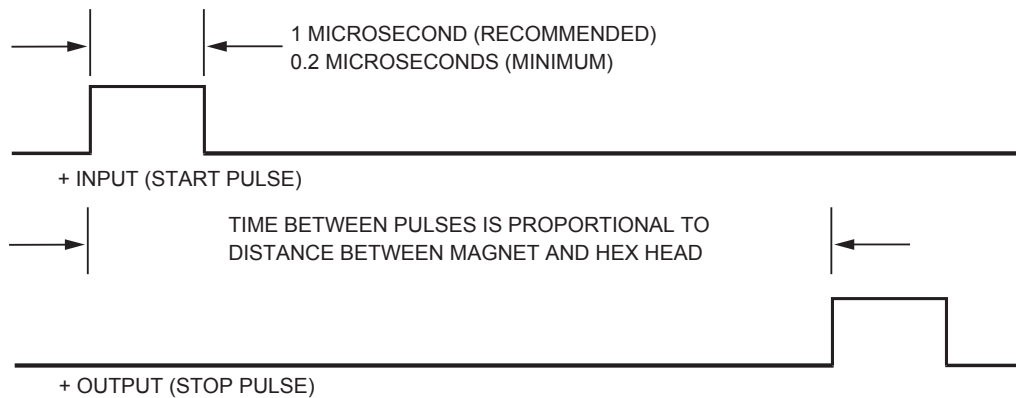


Figure 3-3: 952CP Control Pulse

3.7: 952 VP (Variable Pulse)

The variable pulse signal interface of the BlueOx digital output series is a pulse width modulated signal (RS-422). The maximum cable length for the differential LDTs is 1,500 feet. This LDT can also be configured for external or internal interrogation. External interrogation is when an external device connected to the LDT generates a start pulse. This start pulse should be a minimum of 1.0 microsecond in duration. Within 50 nanoseconds after the leading edge of the start pulse has been received, the LDT will generate an output pulse. The duration of the

output pulse is proportional to the distance from the magnet to the hex head. The order of these two pulses is illustrated in Figure 3-4. The 952VP can also generate internal interrogations. This LDT will continually output pulse width modulated signals. As with a 952VP using an external interrogation, the duration of this output pulse is proportional to the distance from the magnet to the hex head. This is illustrated in Figure 3-5. To wire the 952VP, see Figure 3-7. For proper grounding information, see the beginning of this chapter.

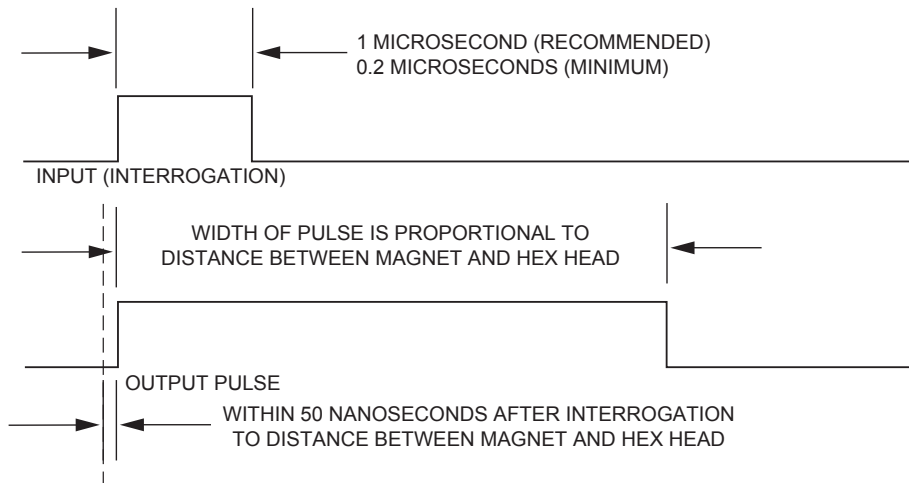


Figure 3-4: 952VP with External Interrogation

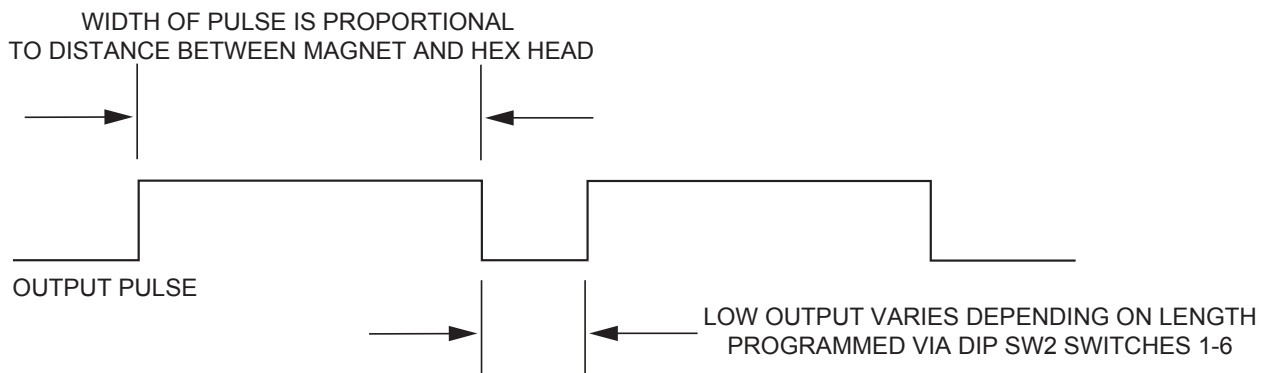


Figure 3-5: 952VP with Internal Interrogation

3.8: 952 RS (Start/Stop)

The start/stop signal interface of the BlueOx digital output series is differential RS-422 output. The maximum cable length for differential LDTs is 1,500 feet. To initiate a start pulse, an external device is used. This start pulse should be a minimum of 1.0 microsecond in duration. Within 50 nanoseconds after the leading edge of the start pulse, the LDT will generate a start pulse of 1.0 microsecond in duration. A stop pulse of 1.0 microsecond in

duration will follow. The time it takes from the leading edge of the start pulse to the leading edge of the stop pulse is proportional to the distance between the magnet to the hex head. The order of these two pulses is illustrated in Figure 3-6. To wire the 952RS, see Figure 3-7. For proper grounding information, see the beginning of this chapter.

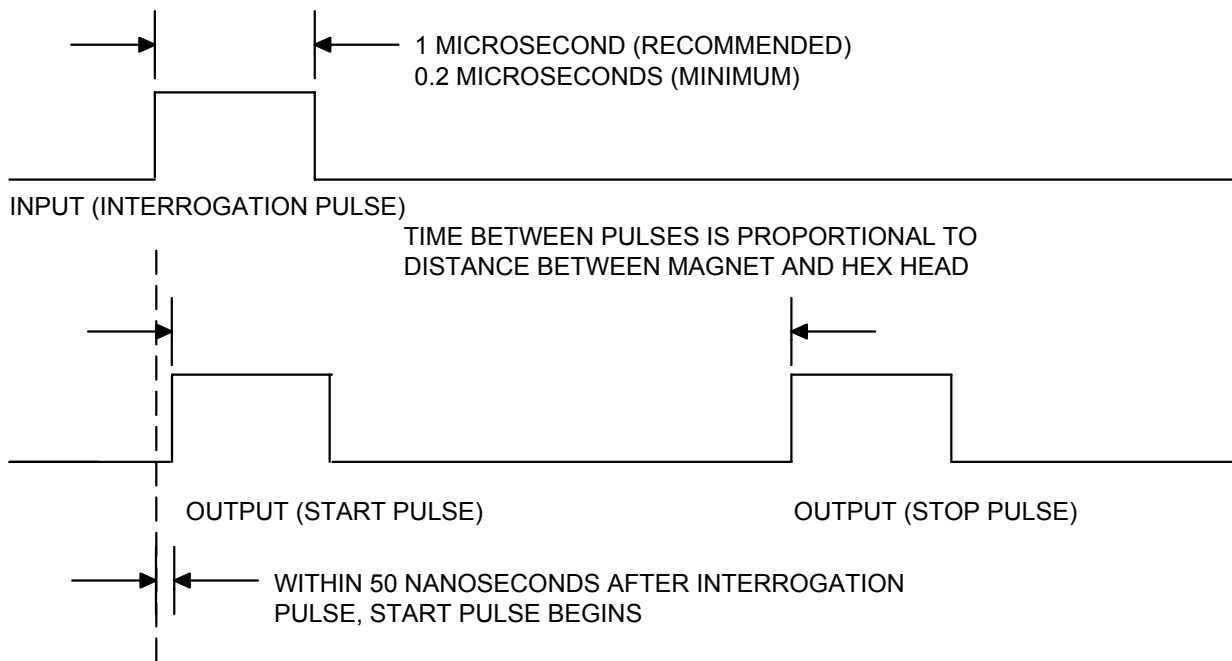
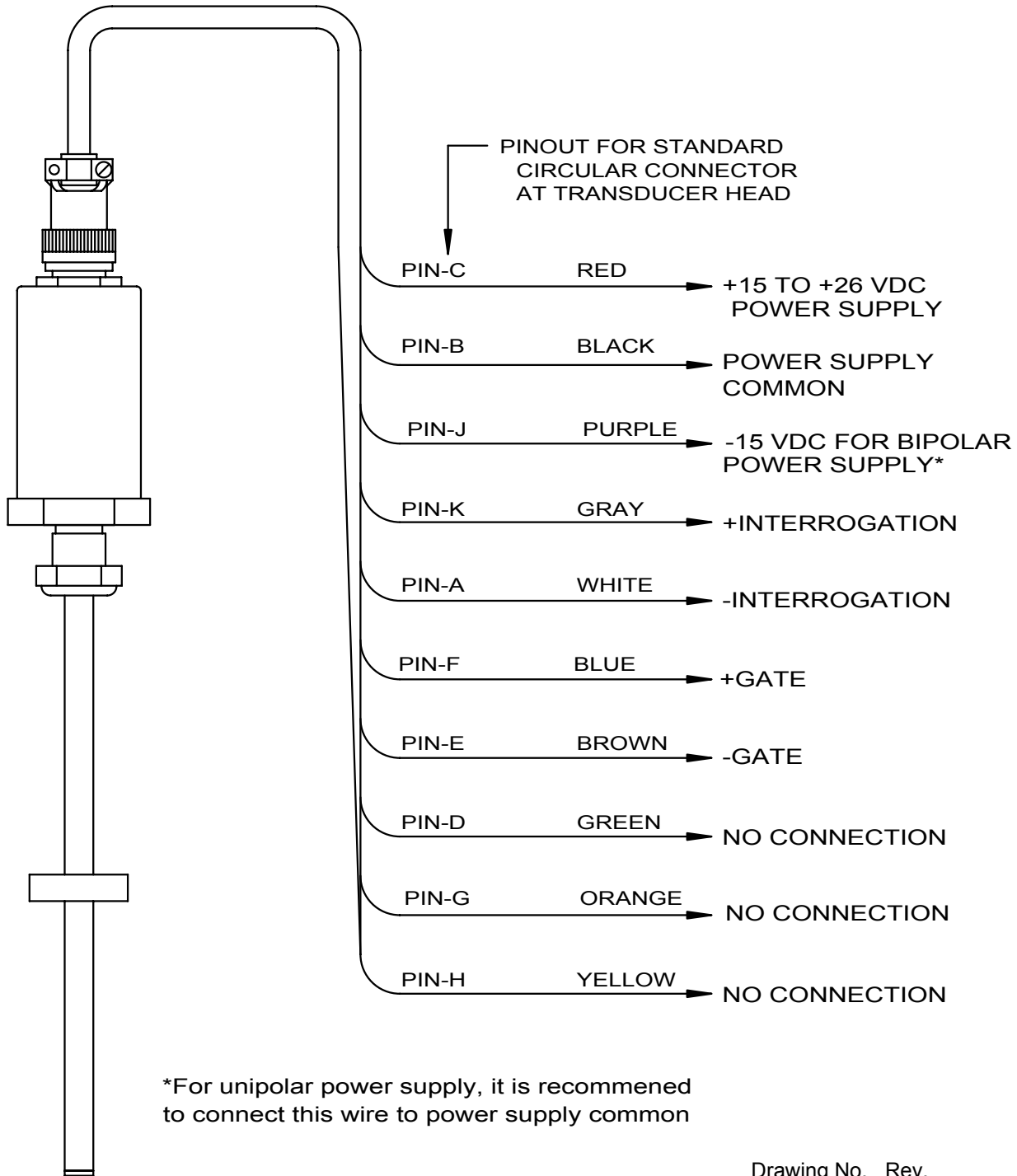


Figure 3-6: 952 RS Start/Stop Pulses

3.9: 952 CP, RS, VP Wiring



Drawing No. Rev.
E0230900 0

Figure 3-7: 952CP, VP, and RS Wiring Drawing



3.10: Setting Zero & Span Position (Analog LDTs Only)

The 952A-V LDT generates a voltage output based on position. The 952A BlueOx with analog output offers 16 bits of resolution and is fully programmable over the entire active stroke length of the LDT. Keep in mind that there is a 2" Null area at the connector end of the LDT and a 2.5" Dead area at the other end of the LDT that the magnet must stay out of at all times. The units come fully programmed from the factory and do not require re-programming unless desired. The analog units are 100% absolute and will not lose programmed parameters on power loss.

To set the ZERO and SPAN position for the LDT follow these steps:

1. Apply power to the LDT.
2. Place magnet assembly where ZERO is to be located, but within the active region of the probe.
3. Momentarily short the program input pin to the power supply common.
4. Place magnet assembly where SPAN is to be located, but within the active region of the probe.
5. Momentarily short the program input pin to the power supply + pin (the maximum distance must be within the active stroke range).

This completes the programming process.

3.11: Differential Analog Output (Options D0, D1 or D2)

The 952A analog LDT's are available with an optional differential analog output. This feature is hardware specific and must be specified at time of order. The differential feature allows the distance between two magnets to be measured. The magnets must remain within the active stroke range at all times and cannot be any closer than 2.5" to each other. Keep in mind that there is a 2" Null area

at the connector end of the LDT and a 2.5" Dead area at the other end of the LDT that the magnet must stay out of at all times. The units come fully programmed from the factory and do not require re-programming unless desired. The analog units are 100% absolute and will not lose programmed parameters on power loss.

The differential feature is user programmable for ZERO and SPAN dimensions and can be programmed anywhere within the active stroke range. The zero can either be programmed for fully open or closed.

To set the ZERO and SPAN position for the probe follow these steps:

1. Apply power to the probe.
2. Move the magnets to the desired minimum (ZERO) setting, but within the active region of the probe.
3. Momentarily short the program input pin to the power supply common.
4. Move the magnets to the desired maximum (SPAN) setting, but within the active region of the probe.
5. Momentarily short the program input pin to the power supply + pin (the maximum distance must be within the active stroke range).

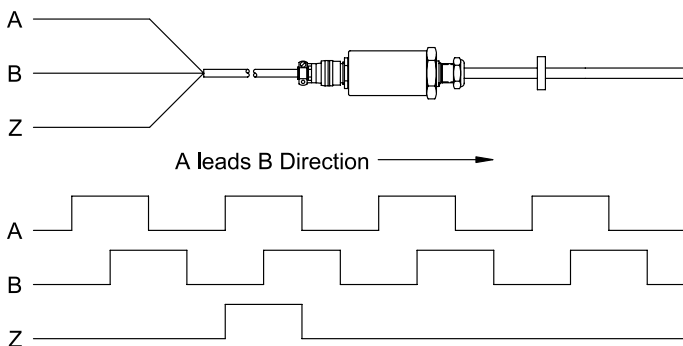
This completes the programming process.

NOTE: The maximum programmable stroke range on units with the differential analog output is 2.5" less than the active stroke. Refer to your part number label or Chapter 1 for active stroke range.

Chapter 4: 952 QD Overview

4.1: Quadrature Output

A new method of interfacing magnetostrictive transducers offers customers an interface as common as analog with the speed and accuracy of pulsed type signaling. The GEMCO 952 QD Linear Transducer provides quadrature output directly from the transducer to the controller (see drawing below). The output from the transducer can be wired directly to any incremental encoder input card, without the need for a special converter module or PLC interface card designed specifically for use with a pulse output magnetostrictive transducer.



The quadrature output provides absolute position data in engineering units. This means that the need for the calibration constant (wire speed) programming has been removed, thereby eliminating the possibility of having an improperly calibrated system. The output signal wires are driven by differential RS-422 line drivers, similar to the drivers used in most magnetostrictive pulse type transducers, providing a high degree of noise immunity.

A unique feature of this transducer is a Burst mode of operation. An input on the transducer triggers a data transfer of all the incremental position data relative to the transducer's absolute zero position. This can be used to achieve absolute position updates when power is restored to the system or anytime an update is needed to re-zero or home the machine. Additionally, another input to the transducer can be used to establish a Zero position for the transducer.

4.2: Signal Connection Application Note

Overview

This application note will attempt to clarify the type of signals coming out of and going into the 952QD quadrature probe.

Inputs

The quadrature probe has two inputs, the Zero and Burst inputs. These inputs are single ended. That is, the connection for each input consists of only one wire, the corresponding signal wire. For these (single ended) inputs, the signal is measured with reference to the power supply ground, which is also sometimes referred to as common.

The quadrature probe is available with either +24 VDC level signal thresholds or TTL level thresholds. The signal voltage level required to activate the input for the +24 VDC level signals is proportional to the power supply voltage that the customer is supplying to the probe. This level is approximately 41% of the power supply voltage. For example; if the power supply voltage powering the probe is exactly +24 VDC, the threshold voltage would be about 9.84 volts.

The TTL level threshold signals are activated when these inputs exceed the typical TTL level threshold, which is 2.0 VDC.

Additionally, for the +24 VDC level signals, the customer can specify either a sourcing or sinking type of input. A sourcing input type is pulled high internal to the probe. To activate a sourcing input, the customer must pull the signal lower than the threshold voltage to activate the input. A sourcing input is usually driven by a sinking output or a switch connected to ground. A sinking input type is pulled low internal to the probe. To activate a sinking input, the customer must pull the signal higher than the threshold voltage to activate the input. A sinking input is usually driven by a sourcing output or a switch connected to the power supply.



It is important that the customer drive the signal levels much greater or lower than the threshold voltages. Asserting a signal with a voltage level close to the threshold voltage could induce multiple activations of that input (or none at all) and therefore produce unexpected results or probe readings.

Outputs

The quadrature probe has three outputs, the A, B and Z outputs. These outputs are differential (also known as balanced). That is, the connection for each output consists of two signal wires. These are typically described as the + and - signals. For example, the A channel consists of A+ and A-. The same applies to the B and Z channels. For these (differential) outputs, the signal is measured with reference to the other signal (i.e. the difference or differential). For example; if the A+ signal voltage is greater than the A- signal, channel A is a logic 1. Conversely, if the A+ signal voltage is lower than the A- signal, channel A is a logic 0. Again, this applies to the B and Z channels as well. Differential type signals are much less prone to interference caused by electrical noise or ground loops more often found in single ended signal connections.

The differential outputs of the A, B, and Z channels are at RS-422 signal levels. RS-422 is a well known TIA/EIA standard and common interface type for incremental encoders. The RS-422 receiver channel (on the PLC or controller side of the connection) typically has what is referred to as a termination resistor connected across the + and - signal pins. The value of the termination resistor is (by RS-422 specifications) typically 100 ohms. However, some receivers will work with greater resistance values and some with no termination resistor at all. For proper signal integrity, especially at higher data rates (i.e. quadrature pulse frequency) a termination resistor of no greater than 1Kohm is recommended.

Driving Single Ended Inputs

A differential output (i.e. our RS-422 drivers) can also, for most but not all cases, be used to drive single ended inputs. Special consideration must be

given to these types of applications. It should be noted the main signal requirements for an RS-422 signal is the differential voltage of the + relative to the - signals and not necessarily the voltage level of any one of these signals with respect to ground (or common). To meet the RS-422 specification, this differential voltage only needs to be ± 0.2 volts. However, an RS-422 driver will typically drive either the + or - signal to around 3.8 volts with respect to ground. This voltage is more than sufficient to drive TTL level inputs as well as other low level inputs. The input voltage level specifications of the PLC or controller being used should be consulted for the actual level required.

When using PLS's or controllers that are not TTL compatible output driver option L should be used. Option L uses a 0L7272 line driver I.C. The output from this driver will be 1 volt less than the LDT's input power.

When physically connecting a differential output to a single ended input, only use the + signal, leaving the - signal unconnected (do NOT connect the - signals to ground). The A+, B+, and Z+ signals should be connected to their corresponding inputs. Insulate and tie back the - signals. See Figure 4-2, Single Ended Interface.

4.3: Quadrature Output Resolution and Speed

The internal resolution of the 952 GEMCO Linear Transducer is 0.001". This would be represented to the encoder input device by specifying an output resolution of 1,000 cycles per inch for the transducer. Although the typical resolution is 1,000 cycles per inch (CPI), the transducer can be ordered with virtually any CPI setting.

For a typical rotary type shaft encoder with incremental quadrature output, the output frequency of the pulses is governed by the resolution of the encoder (pulses per turn) and the rotational speed (RPM) of the encoder. The output pulse rate from the LDT transducer is fixed and is controlled internally and can be specified by the customer. The output frequency must be specified so that it does not exceed the maximum pulse rate of the encoder input card the sensor is connected to. The output pulse frequency range can be ordered from 10KHz to 1MHz.

4.4: 952 QD Wiring Connections

Once the LDT has been installed, wiring connections can be made. There are two groups of connections you will need to make. They are as follows:

- Power Supply Connections (including grounding and shielding)
- LDT Input/Output Connections

Power Supply/Ground Connections

The BlueOx standard cable is Alpha XTRA-GUARD 2 25110 SUPRASHIELD™, a multi-conductor cable with a specially formulated polyurethane jacketing, 10 conductors of 22 ga, with an aluminum/polyester/aluminum foil with drain wire plus an overall braid of tinned copper shield. Cable O.D. is .30. To reduce electrical noise the shield must

be properly used. Connect the cable's shield to the controller system GND. The cable shield is not connected at the transducer end. Always observe proper grounding techniques such as single point grounding and isolating high voltage (i.e. 120/240 VAC) from low voltage (11-28 VDC cables). Whenever possible, this cable should be run in conduit by itself.

In order for the 952QD to operate properly, the LDT's external power supply must provide a voltage between +11 to +28 VDC. The power supply must be rated at 250mA minimum. The power supply should provide less than 1% ripple and 10% regulations. (The power supply should be dedicated to the LDT to prevent noise from external loads from affecting the BlueOx).

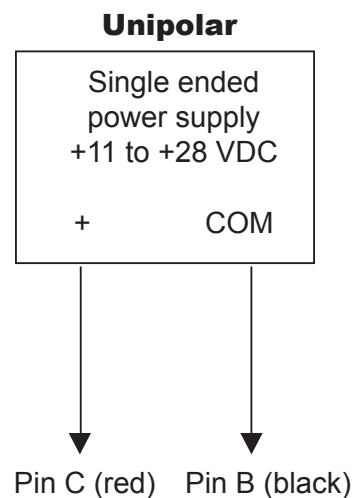


Figure 4-1: Power Supply Wiring

WARNING: Do not route the BlueOx cable near high voltage sources.

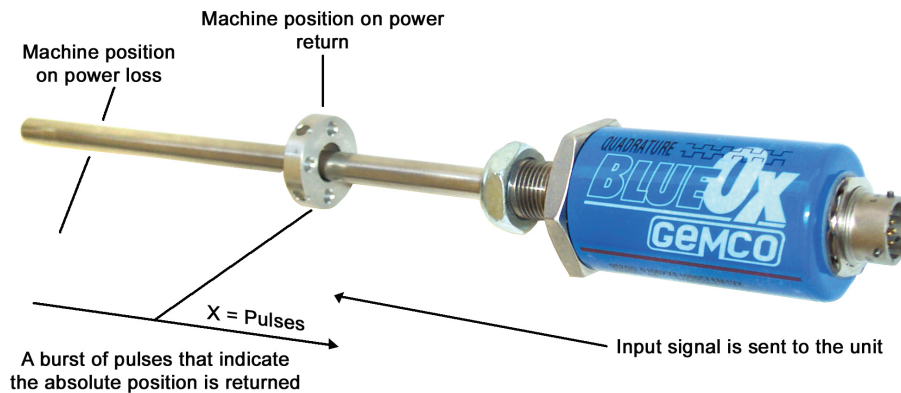
NOTE: The 952QD is only available in a unipolar Supply.

4.5: Features

Burst Mode

Enables the system to be absolute even though data transfer is through incremental method. In the event of power failure, the controller can be programmed to automatically send a signal to the

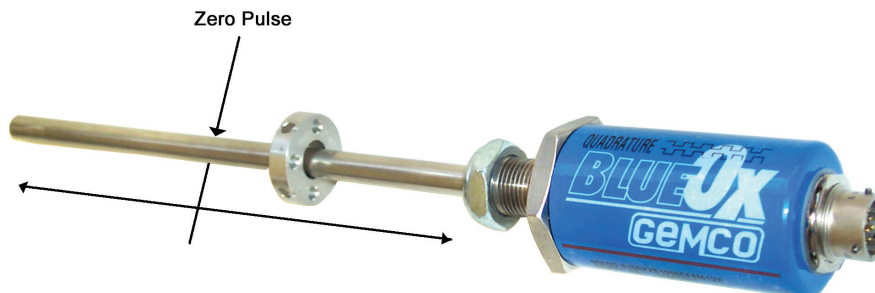
probe then the probe will respond with the current position data. An input signal to the probe will cause a burst of data, representing the absolute position, to be fed back to the controller.



Zero Pulse

By sending a signal to the probe at any time in the stroke, a new zero point can be established. When using the burst input, the absolute position provided will be relative to the established zero position. In probes with volatile storage, the zero point will

be kept until a new zero pulse is sent or until the probe loses power. Probes with nonvolatile storage will store the zero position even if you lose power. The nonvolatile zero can be set 100,000 times; the volatile zero can be set an infinite number of times.



The type of signal needed for the Burst / Zero inputs:

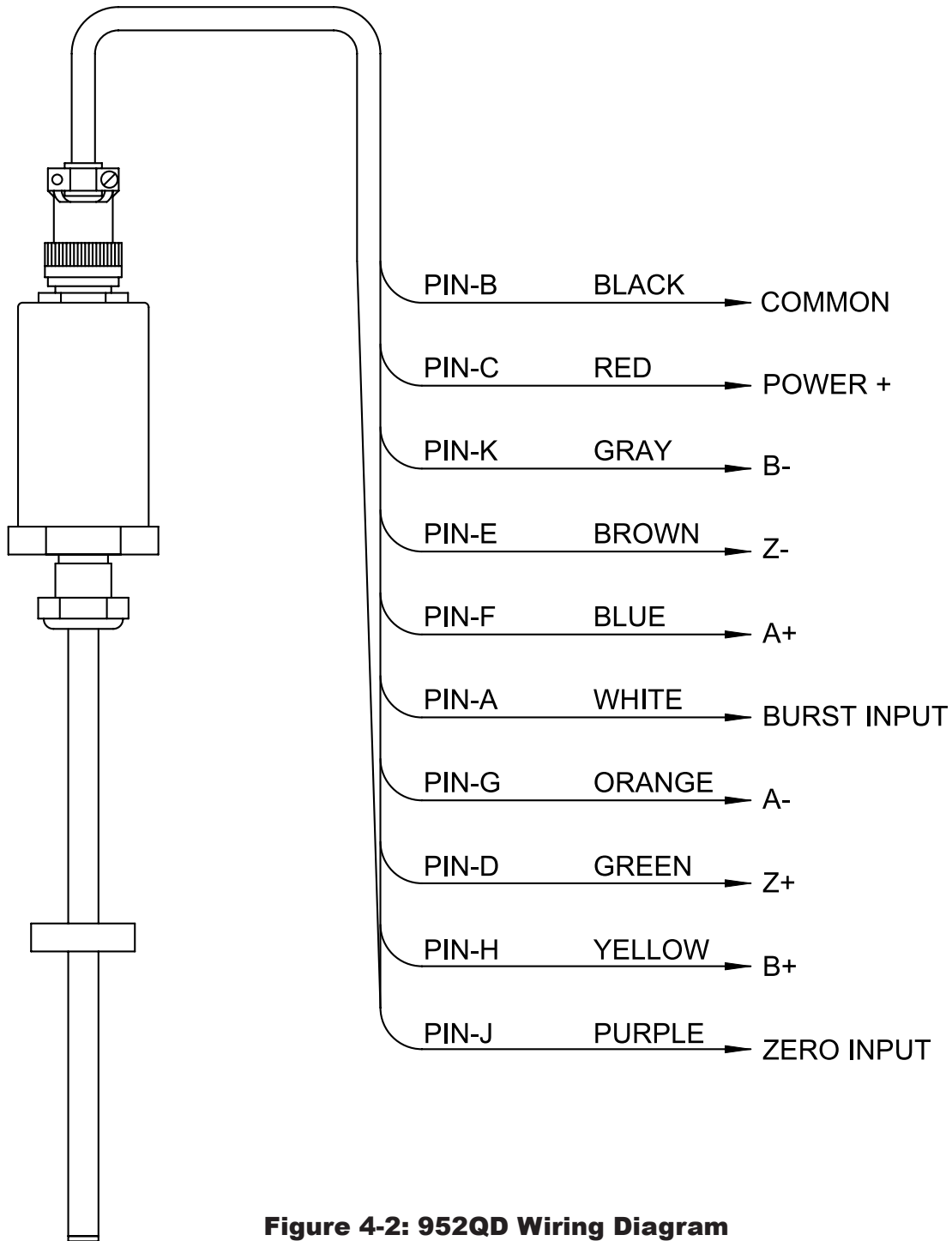
E = Sinking (PLC Sourcing Outputs)

C = Sourcing (PLC Sinking Outputs)

T = TTL

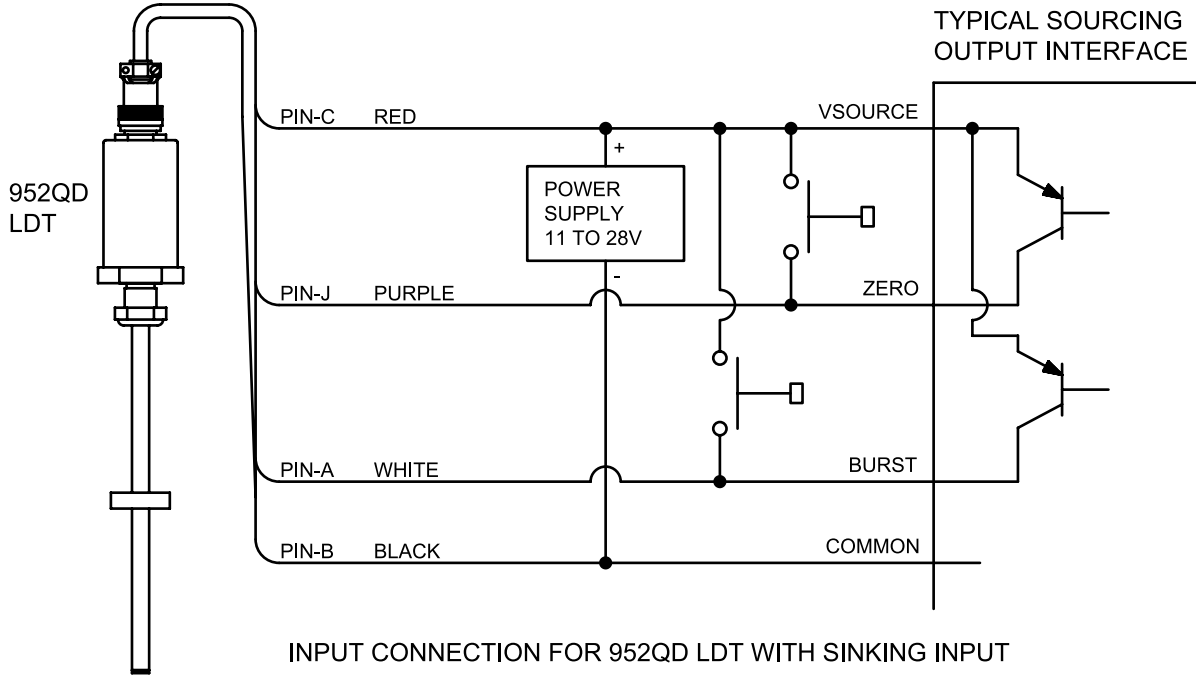
See Appendix C: Specifications for more information or see Figure 4-2.

4.6: 952 QD Wiring Diagram

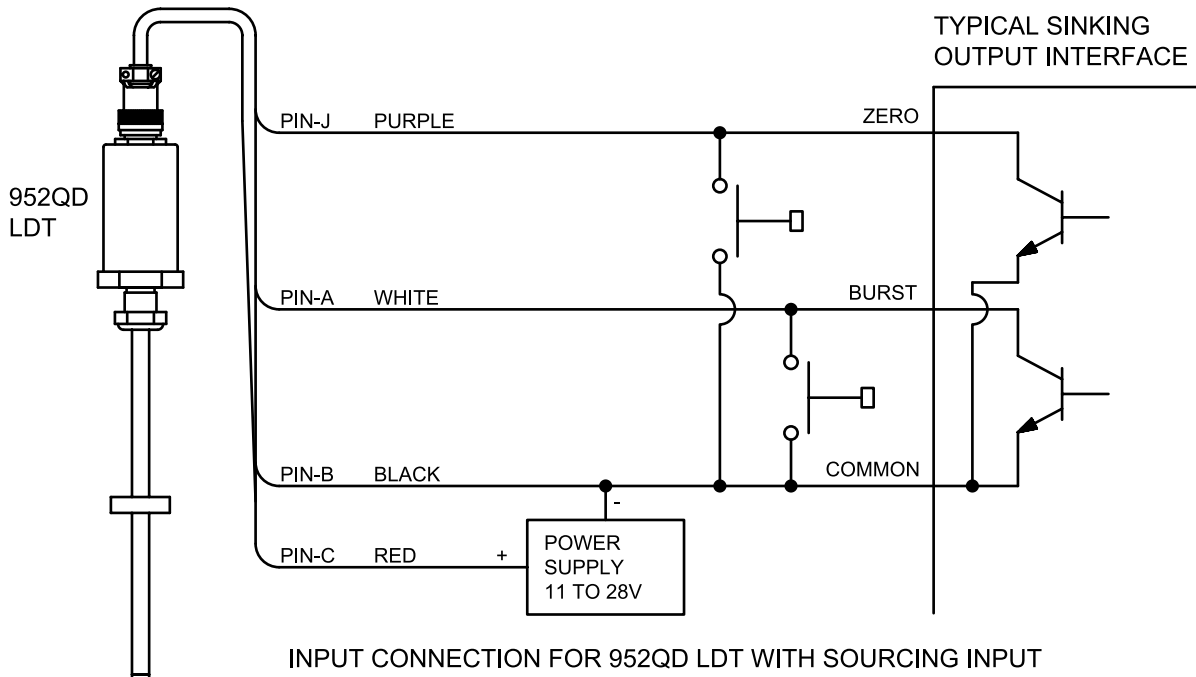


**Figure 4-2: 952QD Wiring Diagram
Drawing E0237900**

CABLE ASSY.
P/N SD0439700LXX

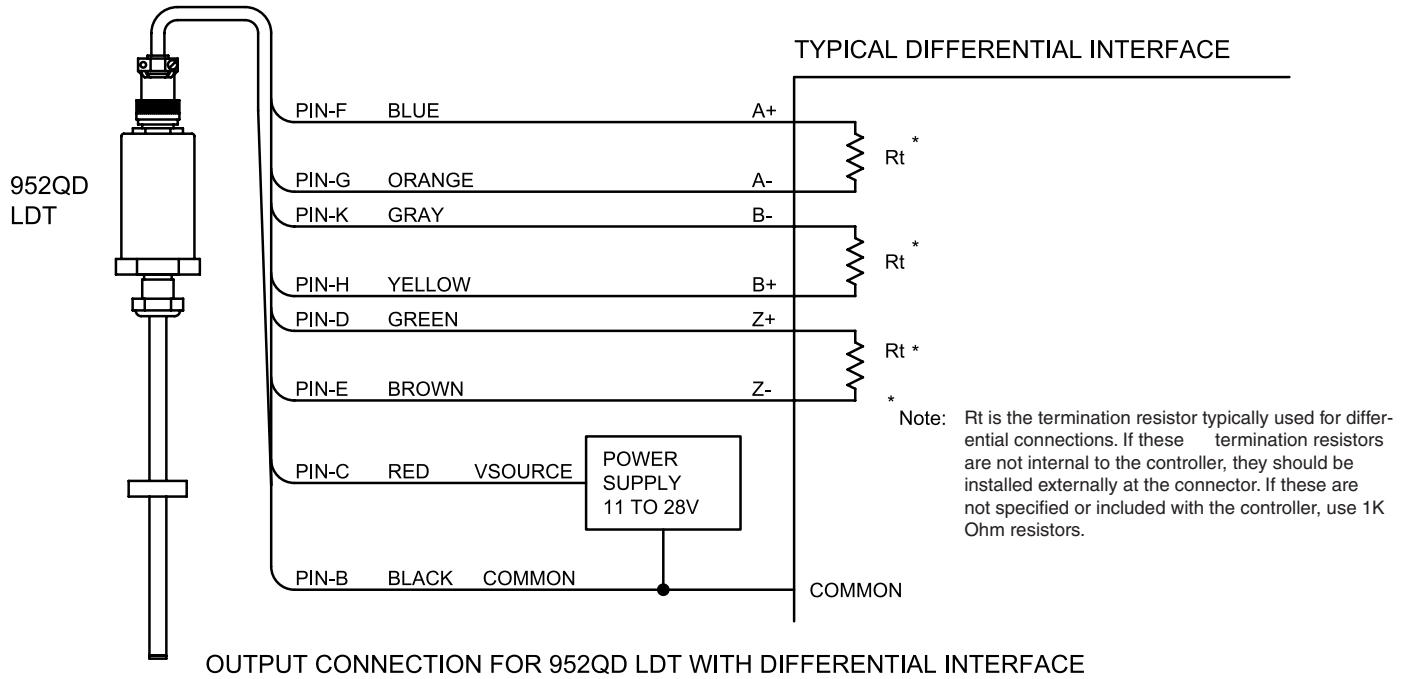


CABLE ASSY.
P/N SD0439700LXX

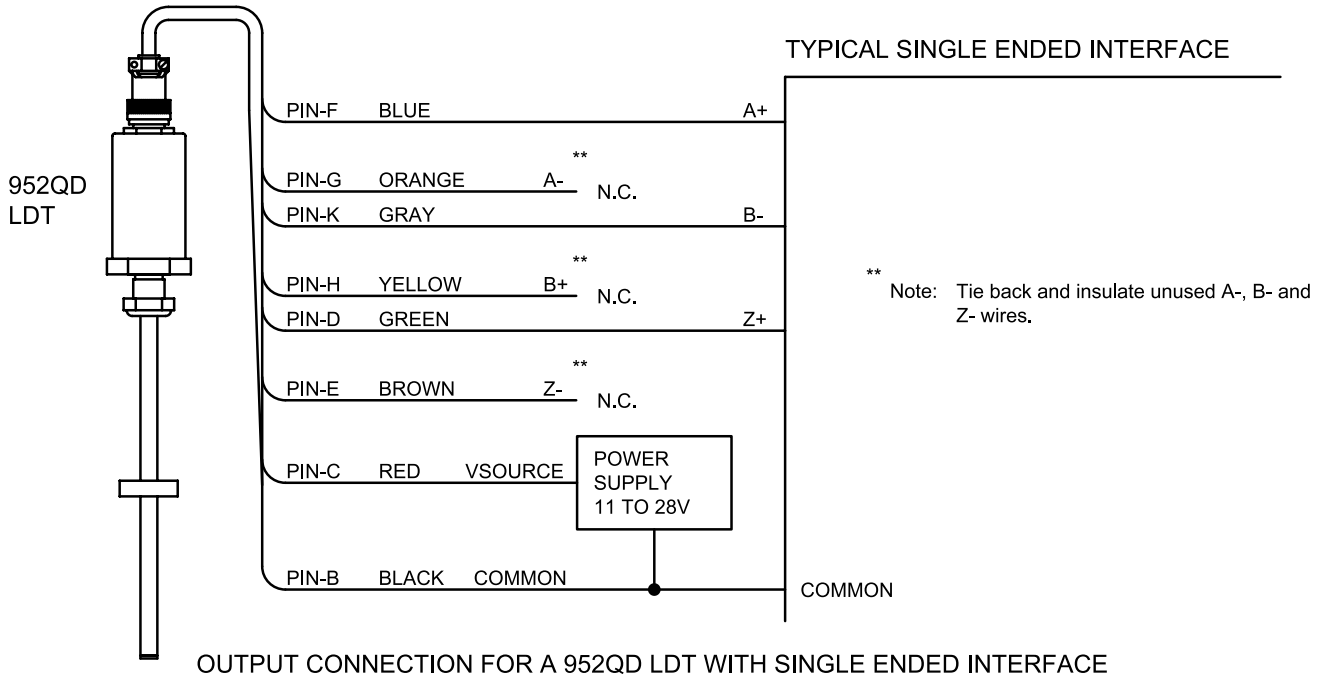


**Figure 4-3: Input Signal Connections for 952 QD LDT
Drawing E0237700**

CABLE ASSY.
P/N SD0439700LXX



CABLE ASSY.
P/N SD0439700LXX



**Figure 4-4: Output Signal Connections for 952 QD LDT
Drawing E0237600**



4.7: 952 QD Frequency

Frequency or Pulse Rate

Selecting the proper frequency in the part number and your controller is very important. The internal clocks inside of the 952QD interrogates the LDT and transmits the incremental pulses at a fixed rate of speed. The frequency or pulse rate of the 952QD is factory set to 10KHZ - 1.00MHZ, consult part numbers for your model. The input to the PLC or display will determine the frequency needed.

Example: If your PLC High Speed counter card or display accepts a 1MHZ encoder input the choices are:

- F1 = 10KHZ
- F2 = 25KHZ
- F3 = 50KHZ
- F4 = 75KHZ
- F5 = 100KHZ
- F6 = 150KHZ
- F7 = 250KHZ
- F8 = 500KHZ
- F9 = 1.00MHZ

NOTE: If your controller's maximum input frequency falls between two available frequencies, choose the lower frequency.



Appendix A: Troubleshooting

A.1: Troubleshooting for 952 QD

Troubleshooting describes common problems that may occur when installing the LDT and offers possible solutions to these problems. If, after reading this appendix, you are unable to resolve a problem, contact factory. Troubleshooting is divided into the following two groups:

- General Checks
- Power Supply

General Checks

Make sure that the magnet is located within the LDT's active stroke area. Captive magnet assemblies should be positioned so that they can move freely over the entire area of the active stroke without binding or pushing on the rod. Non-captive magnet assemblies should be situated so that the magnet is no farther than 0.2" from the rod at any point in the magnet assembly's movement.

NOTE: Ferromagnetic material (material readily magnetized) should be located no closer than 0.25" from the magnet or LDT rod end. This includes mounting brackets, magnet spacers, magnet brackets, and mounting screws. Ferromagnetic material can distort the magnetic field, causing adverse operation or failure of the LDT.

Check all LDT wires for continuity and/or shorts. It is preferable that the cable between the LDT and the interface device be one continuous run. If you are using a junction box, it is highly recommended that the splice junction box be free of AC and/or DC transient-producing lines. The shield should be carried through the splice and terminated at the interface device end.

Unipolar Power Supply Check

This section will help you to determine if your power supply is adequate for the LDT to operate properly, or if the LDT's cable has a short or open.

In order for the BlueOx to operate properly, the external power supply must provide a level between +11 to +28 VDC. A power supply providing voltage above this specified range may damage the LDT. A power supply providing power below this specified range will not be sufficient to power the LDT. When powering more than one BlueOx on a single power supply, remember that each BlueOx requires three (3) watts of power maximum (1 watt typical). The amount of current draw will vary based on the input voltage used. To calculate the current draw for a particular LDT, divide the LDT wattage by the input voltage. For example, 3 watts divided by 24 VDC equals 125mA.

If your LDT is not operating properly, the LDT's cable may have an open or short, or the power supply is not supplying sufficient power. To verify this, perform the following steps:

1. Turn the power supply off.
2. Remove the mating connector from the LDT
3. Turn the power supply on.
4. Using a digital voltmeter, check pins B (GND) and C (+) from the mating end of the cable for a level between +11 and +28 VDC.

NOTE: LDTs with potted cable assemblies should be checked for proper voltage at the power supply terminals. This cable assembly cannot be removed from the LDT.

If reading is between +11 and +28 VDC, turn power supply off and go to step 7. If reading is below +11 VDC, either your power supply is not providing



enough power or the LDT's cable possibly has a short/open. Readings of no voltage or minimal voltage (less than 5 volts) may be due to a short/open in the cable. If reading is not between +11 and +28 VDC, go to step 5. If reading is above +28 VDC, adjust power supply or replace.

5. Turn the power supply off.
6. Check the continuity of the individual wires of the cable between the power supply and the LDT. Check for continuity from one end of the cable to the other. Also, verify that no shorts exist between pins.
7. Reconnect the mating connector to the LDT.
8. Turn power supply on.
9. Using a digital voltmeter, check the power supply's + and - terminals for a voltage between +11 and +28 VDC.

Low voltage readings may indicate a power supply with a wattage (current) rating that is too low. (Each LDT requires 3 watts). If the cabling checks out in step 6 and your voltage is below +11 VDC, check your power supply current rating. If voltage is between +11 to +28 VDC and the LDT is still inoperative, contact factory.



A.2: Troubleshooting for 952 Analog LDTs

Troubleshooting describes common problems that can occur when installing the LDT and offers possible solutions to these problems. If, after reading this appendix, a problem is still unresolved, please contact our technical support department. Troubleshooting is divided into the following two groups:

- General Checks
- Power Supply

General Checks

Make sure that the magnet is located within the LDT's active stroke area. Keep in mind that the LDT is programmable over the entire active stroke area. Refer to Section 3.9 for programming details. Captive magnet assemblies should be positioned so that they can move freely over the entire area of the active stroke without binding or pushing on the rod end. Non-captive magnet assemblies should be situated so that the magnet is no farther than 0.2" from the rod at any point in the magnet assembly's movement.

NOTE: Ferromagnetic material (material readily magnetized) should be located no closer than 0.25" from the magnet or LDT rod end. This includes mounting brackets, magnet spacers, magnet brackets, and mounting screws. Ferromagnetic material can distort the magnetic field, causing adverse operation or failure of the LDT.

Check all LDT wires for continuity and/or shorts. It is preferable that the cable between the LDT and the interface device be one continuous run. If you are using a junction box, it is highly recommended that the splice junction box be free of AC and/or DC transient-producing lines. The shield should be carried through the splice and terminated at the interface device end.

Unipolar Power Supply Check

This section will help you to determine if your power supply is adequate for the LDT to operate properly, or if the LDT's cable has a short or open.

In order for the BlueOx to operate properly, the external power supply must provide a level between 13.5 to 30 VDC. A power supply providing voltage above this specified range may damage the LDT. A power supply providing power below this specified range will not be sufficient to power the LDT. When powering more than one BlueOx on a single power supply, remember that each BlueOx requires three (3) watts of power. The amount of current draw will vary based on the input voltage used. To calculate the current draw for a particular LDT, divide the LDT wattage by the input voltage. For example, 3 watts divided by 24 VDC equals 125mA.

If the LDT is not operating properly, the LDT's cable may have an open or short, or the power supply is not supplying sufficient power. To verify this:

1. Turn the power supply off.
2. Remove the mating connector from the LDT.
3. Turn the power supply on.
4. Using a digital voltmeter, check across power supply common and customer supplied power (+VDC) on the mating end of the cable for a level between 13.5 and 30 VDC.

NOTE: LDT's with potted cable assemblies should be checked for proper voltage at the power supply terminals. This cable assembly cannot be removed from the LDT.

If reading is between 13.5 and 30 VDC, turn power supply off and go to step 7. If the reading is below 13.5 VDC, either the power supply is not providing enough power or the LDT's cable possibly has a short/open. Reading of no voltage or minimal voltage (less than 5 volts) may be due to a short/open in the cable. If reading is not between 13.5 and 30 VDC, go to step 5. If reading is above 30 VDC, adjust power supply or replace.



5. Turn the power supply off.
6. Check the continuity of the individual wires of the cable between the power supply and the LDT. Check for continuity from one end of the cable to the other. Also, verify that no shorts exist between pins.
7. Reconnect the mating connector to the LDT.

A.3: Troubleshooting for 952 CP, RS or VP LDTs

Troubleshooting describes common problems that may occur when installing the LDT and offers possible solutions to these problems. If, after reading this section, there is still an unresolved problem, contact factory. Troubleshooting is divided into the following two groups:

- General Checks
- Power Supply

General Checks

Make sure that the magnet is located within the LDT's active stroke area. Captive magnet assemblies should be positioned so that they can move freely over the entire area of the active stroke without binding or pushing on the rod end. Non-captive magnet assemblies should be situated so that the magnet is no farther than 0.2" from the rod at any point in the magnet assembly's movement.

NOTE: Ferromagnetic material (material readily magnetized) should be located no closer than 0.25" from the magnet or LDT rod end. This includes mounting brackets, magnet spacers, magnet brackets, and mounting screws. Ferromagnetic material can distort the magnetic field, causing adverse operation or failure of the LDT.

Check all LDT wires for continuity and/or shorts. It is preferable that the cable between the LDT and the interface device be one continuous run. If a junction box is being used, it is highly recommended that the splice junction box be free of AC and/or DC transient-producing lines. The shield should be carried through the splice and terminated at the interface device end.

Unipolar Power Supply Check

This section will help determine if the power supply is adequate for the LDT to operate properly, or if the LDT's cable has a short or open.

In order for the BlueOx to operate properly, the external power supply must provide a level between +15 to +26 VDC. A power supply providing voltage above this specified range may damage the LDT. A power supply providing power below this specified range will not be sufficient to power the LDT. When powering more than one BlueOx on a single power supply, remember that each BlueOx requires three (3) watts of power. The amount of current draw will vary based on the input voltage used. To calculate the current draw for a particular LDT, divide the LDT wattage by the input voltage. For example, 3 watts divided by 24 VDC equals 125mA.

If the LDT is not operating properly, the LDT's cable may have an open or short, or the power supply is not supplying sufficient power. To verify this, perform the following steps:

1. Turn the power supply off.
2. Remove the mating connector from the LDT.
3. Turn the power supply on.
4. Using a digital voltmeter, check pins B (GND) and C (+) from the mating end of the cable for a level between +15 and +26 VDC.

NOTE: LDTs with potted cable assemblies should be checked for proper voltage at the power supply terminals. This cable assembly cannot be removed from the LDT.

If reading is between +15 and +26 VDC, turn power supply off and go to step 7. If reading is below +15 VDC, either the power supply is not providing enough power or the LDT's cable possibly has a short/open. Readings of no voltage or minimal voltage (less than 5 volts) may be due to a short/open in the cable. If reading is not between +15 and +26 VDC, go to step 5. If reading is above +26 VDC, adjust power supply or replace.



5. Turn the power supply off.
6. Check the continuity of the individual wires of the cable between the power supply and the LDT. Check for continuity from one end of the cable to the other. Also, verify that no shorts exist between pins.
7. Reconnect the mating connector to the LDT.
8. Turn power supply on.
9. Using a digital voltmeter, check the power supply's + and - terminals for a voltage between +15 and +26 VDC.

Low voltage readings may indicate a power supply with a wattage (current) rating that is too low. (Each LDT requires 3 watts). If the cabling checks out in step 6 and the voltage is below +15 VDC, check the power supply current rating. If voltage is between +15 to +26 VDC and the LDT is still inoperative, contact factory.

Bipolar Power Supply Check

This section will help determine if the power supply is adequate for the LDT to operate properly, or if the LDT's cable has a short or open.

In order for the BlueOx to operate properly, the external power supply must provide +15 and -15 VDC \pm 10%. A power supply providing voltage above this specified range may cause damage to the LDT. A power supply providing power below this specified range will not be sufficient to power the LDT. When powering more than one BlueOx on a single power supply, each BlueOx requires a maximum of 100mA from each supply rail.

If the LDT is not operating properly, the LDT's cable may have an open or short, or the power supply is not supplying sufficient power. To verify this, perform the following steps:

1. Turn the power supply off.
2. Remove the mating connector from the LDT.
3. Turn the power supply on.
4. Using a digital voltmeter, check pins B (GND) and C (+) from the mating end of the cable for +15 VDC. Also, check from pins B (GND) to J (-) for -15 VDC.

NOTE: LDTs with potted cable assemblies should be checked for proper voltage at the power supply terminals. This cable cannot be removed from the LDT.

If the +15 is between +13.5 and +16.5 and the -15 is between -13.5 and -16.5, turn the power supply off and go to step 7. If the reading is below \pm 13.5 VDC, either the power supply is not providing enough power or the LDT's cable has a short. Readings of no voltage or minimal voltage (less than 5 volts) may be due to a short in the cabling. If reading is not +15 and -15 VDC, go to step 5.

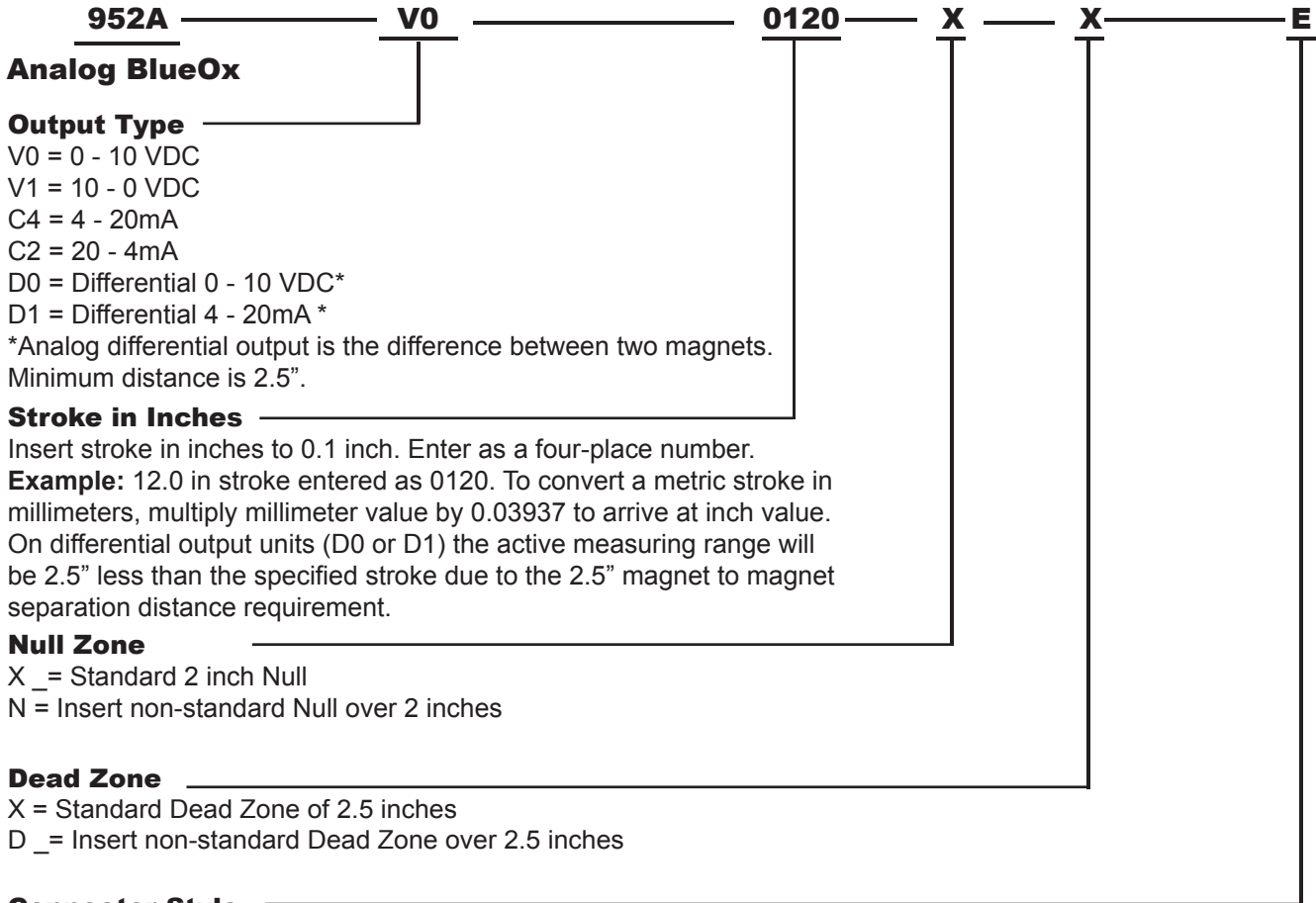
5. Turn the power supply off.
6. Check the continuity of the individual wires of the cable between the power supply and the LDT. Check for continuity from one end of the cable to the other. Also, verify that no shorts exist between pins.
7. Reconnect the mating connector to the LDT.
8. Turn the power supply on.
9. Using a digital voltmeter, check the power supply's +15 and -15 terminals for the proper voltage levels, \pm 15 VDC \pm 10%.

Low voltage readings may indicate a power supply with a wattage (current) rating that is too low. (Each LDT requires 100mA from both the + and - supply rails.). If the cabling checks out in step 6 and the voltage is below \pm 15 VDC \pm 10%, check the power supply current rating. If voltage is at \pm 15 VDC \pm 10% and the LDT is still inoperative, contact factory.



Appendix B: Ordering Information

B.1: Analog Part Numbering



952A ————— **V0** ————— **0120** ————— **X** ————— **X** ————— **E**

Analog BlueOx

Output Type

- V0 = 0 - 10 VDC
- V1 = 10 - 0 VDC
- C4 = 4 - 20mA
- C2 = 20 - 4mA
- D0 = Differential 0 - 10 VDC*
- D1 = Differential 4 - 20mA *

*Analog differential output is the difference between two magnets. Minimum distance is 2.5".

Stroke in Inches

Insert stroke in inches to 0.1 inch. Enter as a four-place number.
Example: 12.0 in stroke entered as 0120. To convert a metric stroke in millimeters, multiply millimeter value by 0.03937 to arrive at inch value. On differential output units (D0 or D1) the active measuring range will be 2.5" less than the specified stroke due to the 2.5" magnet to magnet separation distance requirement.

Null Zone

- X _ = Standard 2 inch Null
- N = Insert non-standard Null over 2 inches

Dead Zone

- X = Standard Dead Zone of 2.5 inches
- D _ = Insert non-standard Dead Zone over 2.5 inches

Connector Style

- S = Standard 12mm 5 pin Euro Connector (CE Approved)
 - E = Environmental MS Connector*
 - C _ = Potted Pigtail Cable Assembly. Insert Pigtail length in feet.
 - T = Threaded Metal Connector (fits MTS® - RB on Tempo II™ or III)
 - Q = Bayonet Style Connector (fits MTS® - RC on Tempo II™ or III)
 - M = 1/4 Turn Quick Disconnect (fits MTS® - MS on Tempo II™ or III)
- Consult factory for other connector options.

* If option S or E (environmental connector) is selected, mating connector and/or pigtail must be ordered separately. **NOTE 1:** On unsupported stroke lengths greater than 4 feet, rod support bracket(s) and a special magnet should be used. **NOTE 2:** Specify magnet as separate line item (standard magnet is SD0400800).

MTS® is a Registered Trademark of MTS Systems Corp.



B.2: Digital Part Numbering

952VP 0120 X - X E I 001

CP = Control Pulse
VP = Variable Pulse
RS=RS422Start/StopPulse

Stroke in Inches
 Insert stroke in inches to 0.1 inch. Enter as a four-place number. **Example:** 12.0 in stroke entered as 0120. To convert a metric stroke in millimeters, multiply millimeter value by 0.03937 to arrive at inch value.

Null Zone
 X = Standard 2 inch Null
 N _ = Insert non-standard Null over 2 inches

Dead Zone
 X = Standard Dead Zone of 2.5 inches
 D _ = Insert non-standard Dead Zone over 2.5 inches

Connector Style
 E = Environmental MS Connector*
 C _ = Potted Pigtail Cable Assembly. Insert Pigtail length in feet.
 T = Threaded Metal Connector (fits MTS - RB on Tempo II™ or III) (RS and VP only)
 Q = Bayonet Style Connector (fits MTS - RC on Tempo II™ or III) (RS and VP only)
 M = 1/4 Turn Quick Disconnect (fits MTS - MS on Tempo II™ or III) (RS and VP only)

Interrogation Mode (with VP only)
 I = Internal Interrogation
 E = External Interrogation

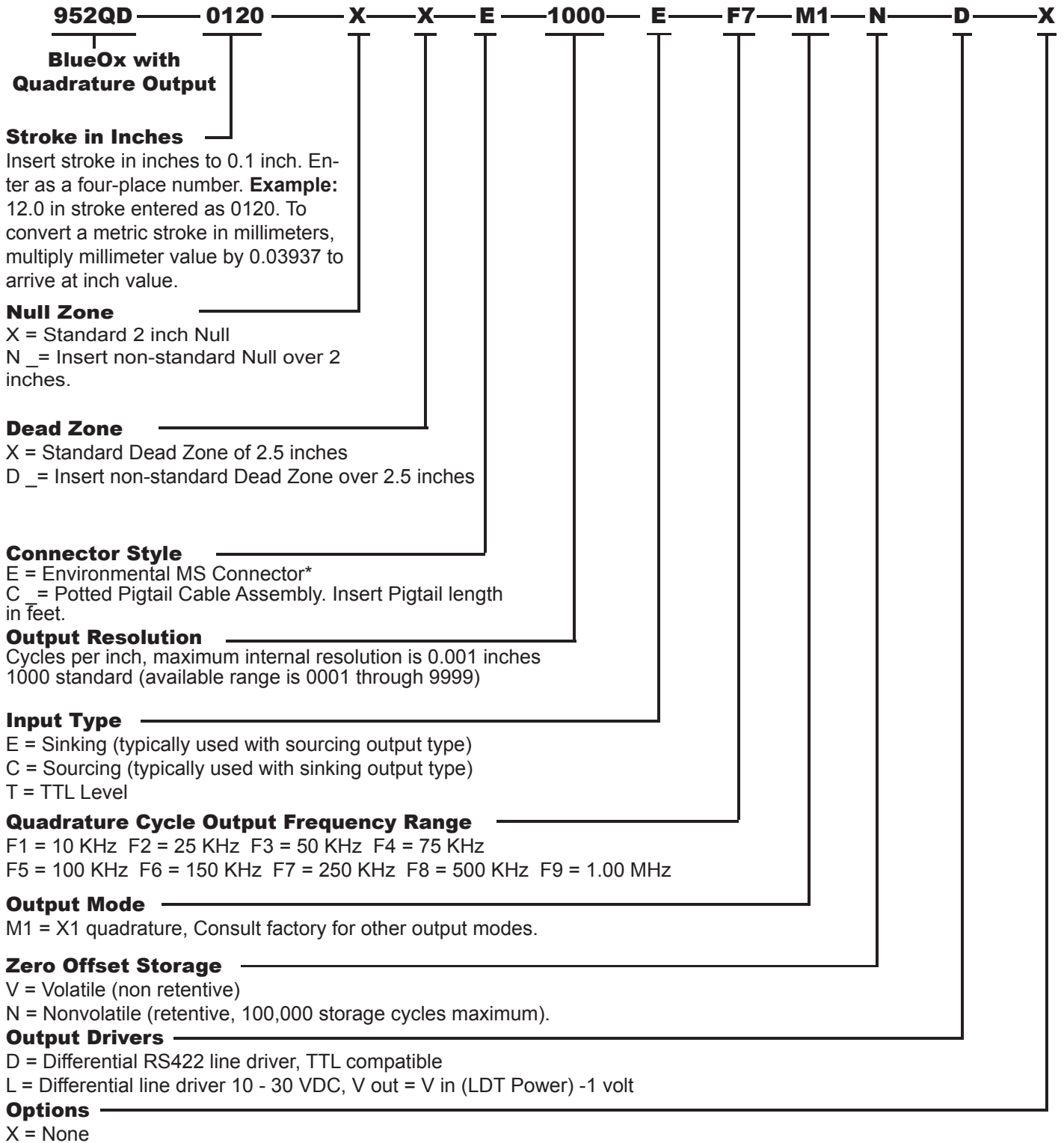
Recirculations Required (with VP only)
 001 (standard) to 127

* If option E (environmental connector) is selected, mating connector and/or pigtail must be ordered separately. **NOTE 1:** On unsupported stroke lengths greater than 4 feet, rod support bracket(s) and a special magnet should be used. **NOTE 2:** Specify as magnet separate line item (standard magnet is SD0400800).

WARNING: Not for use with a GEMCO interface.



B.3: Quadrature Part Numbering



* If option E (environmental connector) is selected, mating connector and/or pigtail must be ordered separately.

NOTE: Consult factory for custom configurations.



Appendix C: Specifications

General Specifications	
Rod End	316 Stainless Steel, 0.405" (10.29 mm) outer diameter
Mounting Hex	316 Stainless Steel, 1.75" (44.45 mm) across flats
Mounting Threads	3/4-16 UNF-2B x 1.00" (25.4 mm) with ESNA Jam Nut and O-ring seal
Head Assembly	Thick Wall Aluminum Cover with Viton O-ring Standard Gasket Seal at the Base and Connector Exit, NEMA 4 (Type 6 optional, consult factory).
Connector	1/4 turn MS-Style Standard (quick connect/disconnect) Connector. Consult factory for other options
Displacement	Up to 168"
Electromagnetic Compatibility	IEC 801-2, Level 3 (Electrostatic discharge requirements) IEC 801-4, Level 3 (Electrical fast transient/burst requirements)
Dead Band	2.50" (63.5 mm) standard
Null Zone	2.00" (50.8 mm) standard
Head Enclosure	3" (76.20 mm) high with 1.75" (44.45 mm) diameter; hex and cover are NEMA 4

Electrical Specifications	
Input Voltage Unipolar	Analog: 13.5 to 26.4 VDC Digital: 13.5 to 26.4 VDC
Bipolar	±15 VDC ±10% (Digital Units Only) Quadrature: 11 to 28 VDC
Current Draw Unipolar Bipolar (Digital LDT Only)	3 watts maximum, 200mA at 15 VDC (1 Watt, Typical) 100mA maximum @ +15 VDC, 100mA maximum @ -15 VDC
Nonlinearity	Less than +/- 0.05% *
Repeatability	+/-0.001% of full stroke or 0.002" (0.0254 mm), whichever is greater.
Hysteresis	+/- 0.02% *
Temperature Coefficient LDT	Less than 0.00011 in./Degree F + [3 PPM/Degree F/in. of Full Stroke] (Less than 0.00503 mm/Degree C + [5.4 PPM/Degree C/mm of Full Stroke]).
Operating Temperature Head (Electronics) Guide Tube	-40° to +158° F (-40° to +70° C) -40° to +220° F (-40° to +105° C)
Storage Temperature	-40° to 185° F (-40° to +85° C)
Operating Pressure	5000 psi Operational, 10,000 psi Spike
Shock & Vibration Vibration Shock	30 Grms. 2000 G.
* Specifications are based on a typical 36" stroke length.	



Analog Specifications	
Analog Output Drift	10ppm/Degree F (18ppm/DegreeC)
Analog Output Loading	Voltage Output Minimum Load Resistance: 2Kohm Current Output Maximum Load Resistance: (Vin - 2)/0.02 Output Current: Guaranteed 6mA minimum for voltage units
Analog Ripple	<1 mV maximum (position output)
Update Time	1mS (stroke lengths 1" to 50") 3mS (stroke lengths 101" to 150") 2mS (stroke lengths 51" to 100") 4mS (stroke lengths 151" to 168")
Position Output	0 - 10 VDC, 16 Bits (65,535) resolution 4 - 20mA, 16 Bits (65,535) resolution
CE Approved with Connector Option "S" Only	
Output May Vary by 0.1% when Subjected to Severe Levels of Electrical Noise	

Digital Specification	
Update Time	Controller Dependent
Digital Output	CP RS-422 Control Pulse RS RS-422 Start/Stop VP RS-422 Pulse Width Modulated (BCD, Binary, or Gray Code Outputs available from 2120 Interface Module.)

Quadrature Specification	
Digital Output	1) Quadrature A: RS-422 differential 2) Quadrature B: RS-422 differential 3) Zero (index) position: RS-422 differential maximum 5V, minimum 2V into a 50Ω load
Digital Input	1) Zero position set: 5-30V Source or Sink 2) Burst mode input: 5-30 Source or Sink Input impedance: 5KΩ Sink threshold: Input < 0.41 x VPS. (Power Supply Voltage) i.e.: 0.41 x 24VDC Power Supply = <9.84VDC Source threshold: Input > 0.41 x VPS. (Power Supply Voltage) i.e.: 0.41 x 24VDC Power Supply = >9.84VDC TTL threshold: Input > 2.1V



Glossary

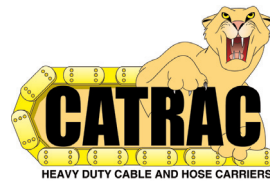
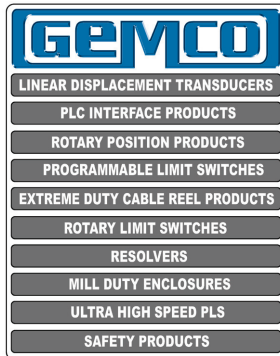
Active Stroke Area	The area designated by the operator on the rod on which the magnet assembly moves.
Burst Input	An input signal to the probe will cause a burst of data, representing the absolute position to be fed to the controller. NOTE: This only applies to the quadrature LDT.
Bipolar Power Supply	A power supply that provides both +15 and -15 VDC.
Connect/Disconnect Connector	A connector which can be quickly connected or disconnected from the LDT's terminals by turning the connector 1/4 of a turn and then pulling.
Dead Band	An area usually 2.5" from the end of the rod where sensing of the magnet is not possible.
External Device	A device wired to the LDT which generates external interrogations.
External Interrogations	Pulses sent by an external device to the LDT, usually to initiate a pulse sequence.
Head Assembly	An enclosure used to house the LDT's electronic components.
Incremental	A relative position feedback device whose signal is always referenced to the zero position. The LDT produces a digital, square wave pulse train that is fed into an up/down counter chip or clock to derive position.
Input Type	Used on 952 QD to determine input type for Burst and Zero modes. ie; sinking, sourcing or TTL.
Internal Interrogations	Pulses generated by the LDT usually to initiate a pulse sequence.
Jam Nut	A nut which screws onto the threads protruding from the hex mounting base. This nut is used to secure the head of the LDT to the user's mounting fixture.
LDT	Linear Displacement Transducer
Magnet Assembly	A non-ferrous ring that moves across the LDT's rod end.
Mounting Hex Base	A non-ferromagnetic base of the mounting hex. This point is where the mounting hex threads begin to protrude from the mounting hex. This hex can be used when tightening the LDT into a bracket.
Non-Volatile	Position is held in memory and will not be lost on power down.
Null Zone	An area usually covering 2.0" on the rod beginning at the threads protruding from the hex mounting base; the area on the rod end which follows the standard null going toward the tip of the rod end is the active stroke area.
Output Resolution	Used in 952 QD to determine amount of pulses per inch.
Potted Cable Assembly	An interface cable that is permanently installed on the LDT at the factory.
Quadrature	Two output channels out of phase by 90 electrical degrees.
Quadrature Cycle Output Frequency	The frequency at which the pulse rate is transmitted out of a quadrature probe.



Recirculations	The method used to improve the resolution of a system using a digital LDT. The On time of a pulse width output is multiplied by a specified factor (from 1-127). This multiplication provides more counting time for the counter in the customer's electronics, thus improving the resolution. The only disadvantage to higher recirculation numbers is the time needed to process the signals.
Return (Stop) Pulse	A pulse generated by the BlueOx to determine the location of the magnet assembly on the rod end.
Rod	A stainless steel tube on which the magnet assembly travels.
RS422 Differential	Differential line driver.
Start Pulse	A pulse generated by either an external device or the LDT to start a pulse sequence.
Stop Pulse	(See Return Pulse)
Unipolar Power Supply	A power supply that provides a single voltage.
Volatile	Position held in memory that is lost on power down.
Wire Speed	The average time it takes a pulse to travel one inch on the wire.
Zero Pulse	By sending a signal to the probe at any time in the stroke a new zero point can be established. (952 QD only)



Other Products



Copyright 2005 by AMETEK AUTOMATION & PROCESS TECHNOLOGIES. All Rights Reserved. Made in the USA.



1080 N. Crooks Road, Clawson, MI 48017-1097
Phone: 248.435.0700 Toll Free: 800.635.0289
Fax: 248.435.8120 www.AMETEKAPT.com

952.M3R
6/10.Z117
500

