

Brake Products Inc

www.brakeproducts.com

888 861-8777

888 629-3592 Fx

sales@brakeproducts.com

REV.	DESCRIPTION	REVISION	DATE	BY
1A	UPDATED DRAWING BORDER		12/20/95	J.S.B.

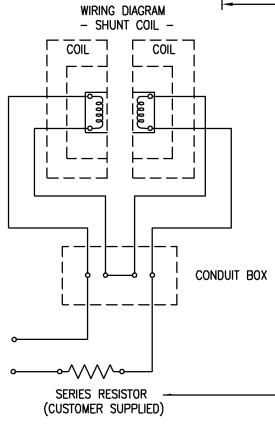
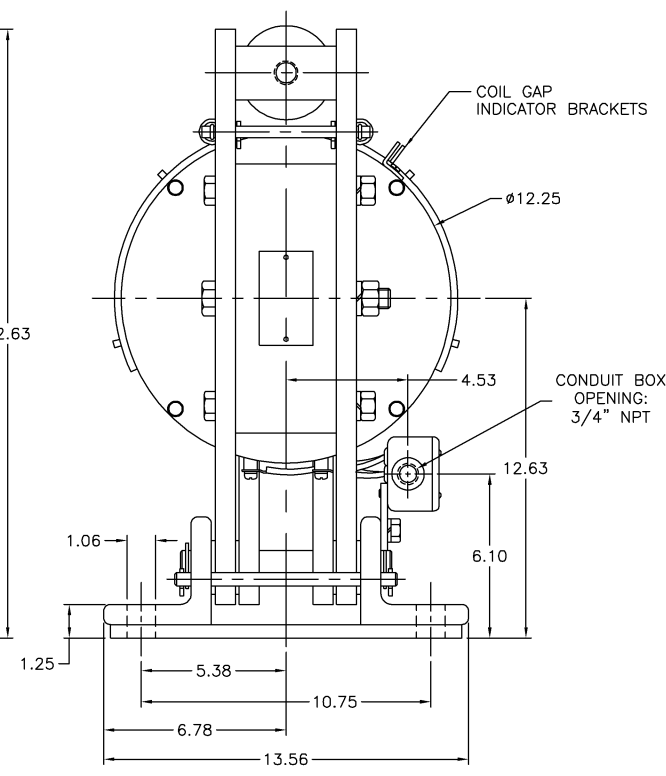
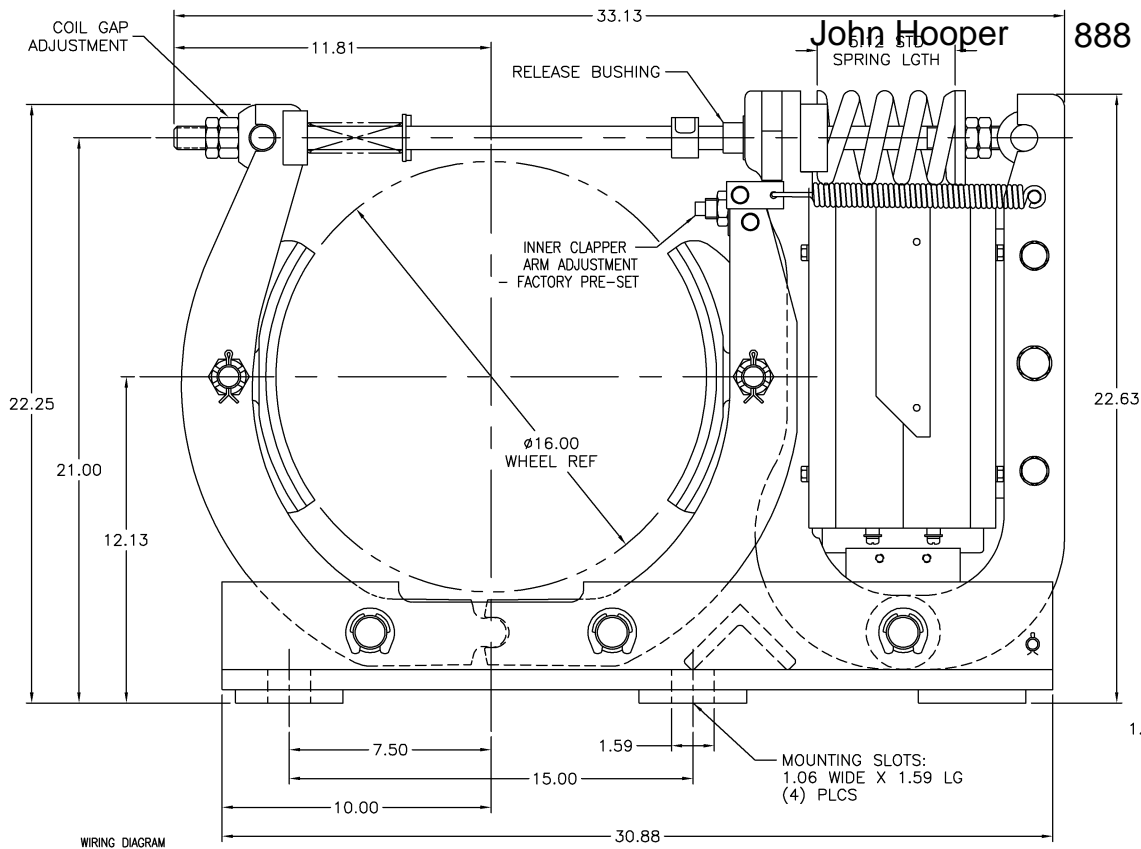

NON-STANDARD TORQUE RATINGS	
TORQUE LB.FT.	MAIN SPRING LENGTH (INCHES)
650	5.38
750	5.31

	COIL DATA - SHUNT OPERATION	
	CONTINUOUS OPERATION	INTERMITTENT OPERATION
VOLTS DC	32	40
AMPS	3.6	4.53
RESISTOR REQ'D 250VDC (OHMS)	51.5	37.7

NOTES:
 -STANDARD TORQUE RATING: 1000 LB.FT. (MAIN SPRING LENGTH OF 5.12")
 -NORMAL MAGNET TRAVEL: .13"
 -WEIGHT OF BRAKE W/O WHEEL: 490 LBS.
 -STANDARD RIGHT HAND MOUNTING SHOWN. FOR LEFT HAND MOUNTING, POSITIONS OF CONDUIT BOX AND SHOE BOLT HEADS ARE REVERSED.

APPROVAL PRINT
 APPROVED FOR CONSTRUCTION
 By: _____
 DATE: _____

THIRD ANGLE PROJECTION	<small> COPYRIGHT © 2004 AMETEK AUTOMATION & PROCESS TECHNOLOGIES. ALL RIGHTS RESERVED. DRAWING IS PROPERTY OF AMETEK AUTOMATION & PROCESS TECHNOLOGIES. UNAUTHORIZED USE, REPLICATION OR DISTRIBUTION IS STRICTLY PROHIBITED BY FEDERAL LAW. </small>	DR. J.S.B.	TITLE
<small> SURFACE FINISH UNLESS OTHERWISE SPECIFIED: $\sqrt{63}$ </small>		DATE 10/25/95	DIMENSION DRAWING TMSC16 BRAKE SHUNT COIL
<small> TOLERANCE ALLOWANCE UNLESS OTHERWISE SPECIFIED: +/- 0.010 ON 2 PLACE DECIMALS +/- 0.005 ON 3 PLACE DECIMALS +/- 0.0005 ON 4 PLACE DECIMALS +/- 30 MIN. ON ALL ANGLES </small>	AUTOMATION & PROCESS TECHNOLOGIES Clawson, MI 48017 U.S.A.	APP.	
		DATE	REV. SIZE
		SCALE	
		5/16	PD-0074900 A C